

SERVIER

35

35

LVS VISO

PROTÈGE CÂBLES ◦ CABLE COVERS

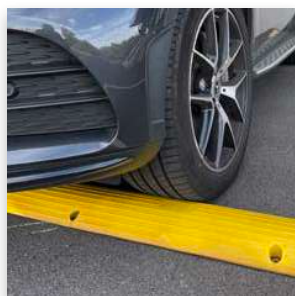
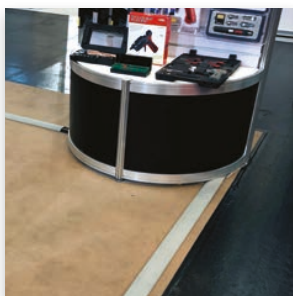

CÔNES ◦ CONES

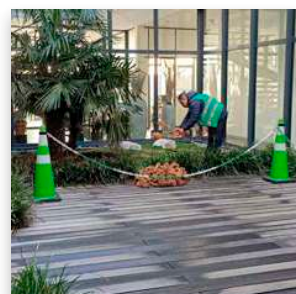

RAMPES ◦ RAMPS

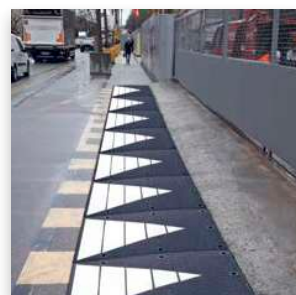

BALISAGE ◦ SAFETY MARKING

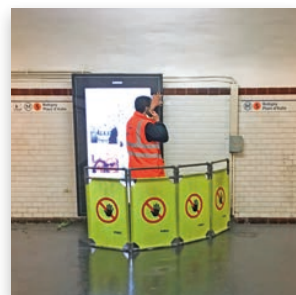

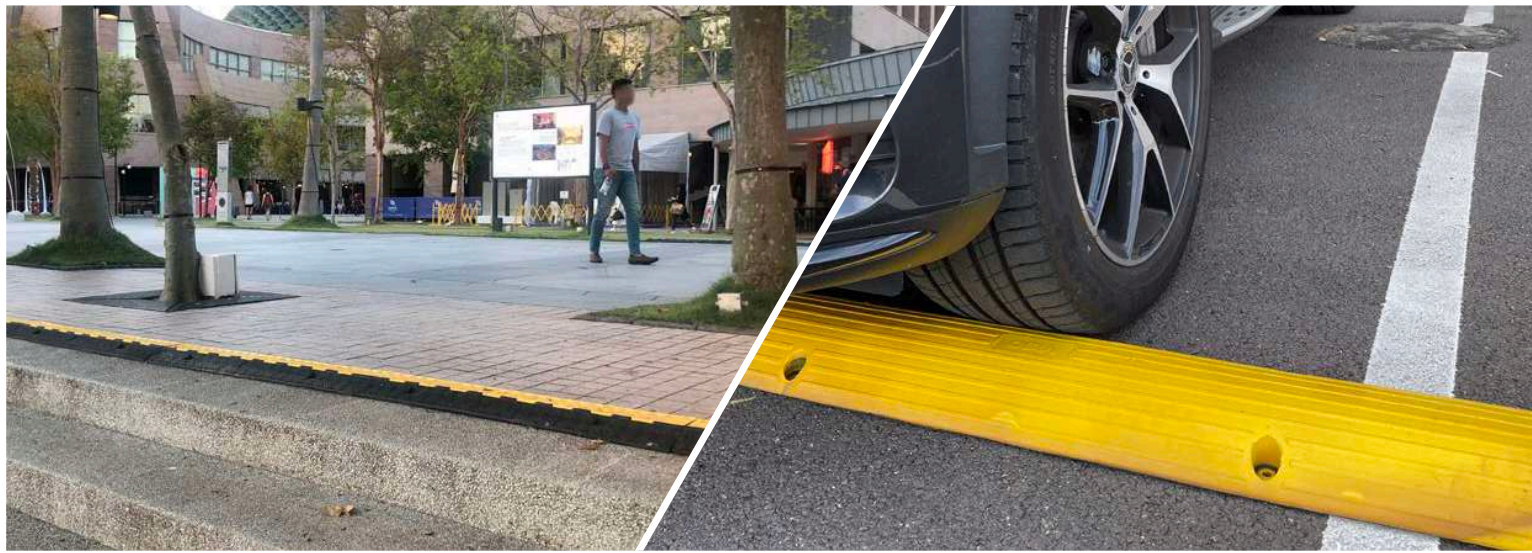

PASSE-CÂBLES ○ CABLES COVERS ○ PROTECTOR DE CABLES ○ KABELBRÜCKEN

CPB 702

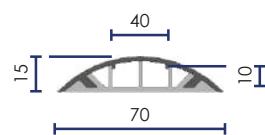
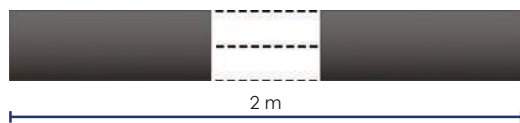

CPB 653

▶ 3 M

CPB 1023

CPB 655

▶ 5 M

CPB 1025

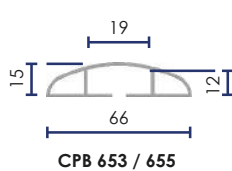

CPB 653 / 655

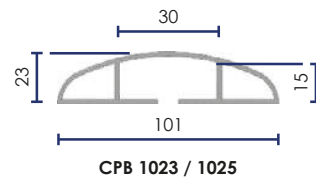

CPB 1023 / 1025

CP 5040

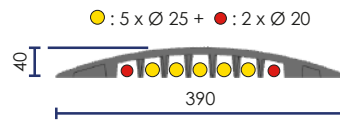
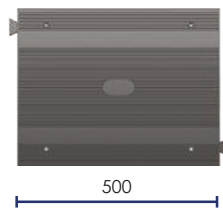

CP 202 / 402

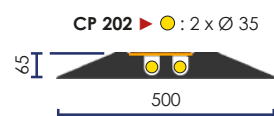

CP 202 ▶ : 2 x Ø 35

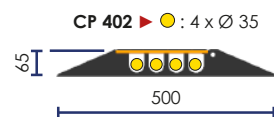

CP 402 ▶ : 4 x Ø 35

CP 1081

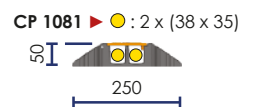
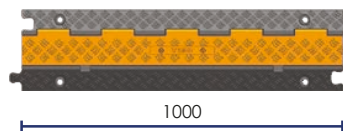

CP 1081 ▶ : 2 x (38 x 35)

CP 1002 / 1031 / 1071

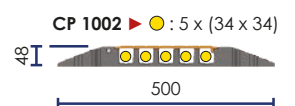
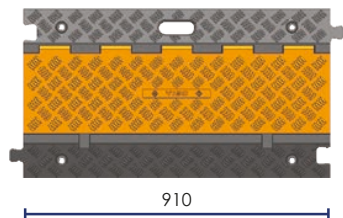

CP 1002 ▶ : 5 x (34 x 34)

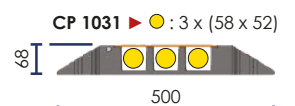

CP 1031 ▶ : 3 x (58 x 52)

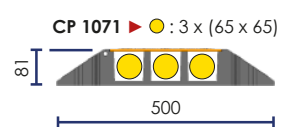

CP 1071 ▶ : 3 x (65 x 65)

CPK 800 / 1100

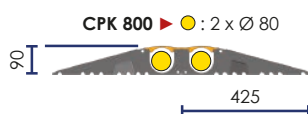
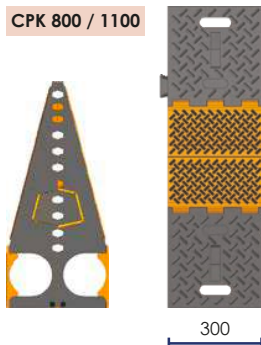

CPK 800 ▶ : 2 x Ø 80

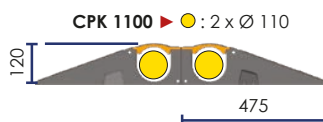

CPK 1100 ▶ : 2 x Ø 110



PASSE-CÂBLES ◦ CABLES COVERS ◦ PROTECTOR DE CABLES ◦ KABELBRÜCKEN

CP 500 / 800 / 1200

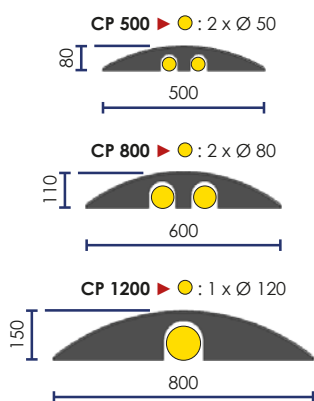

CPO 600 / 850 / 1000

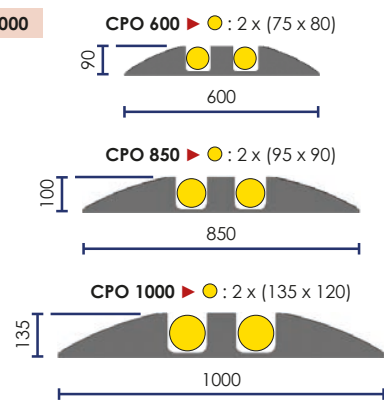

WP 100 ▶ 10 M
WP 170 ▶ 4 M

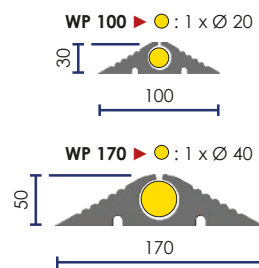

WP 240

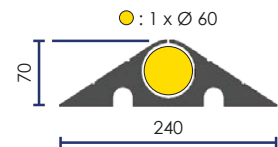
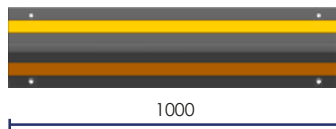

CP 450

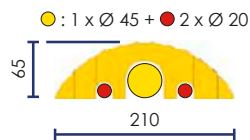
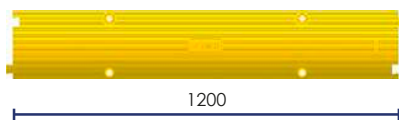

SAFETY 100

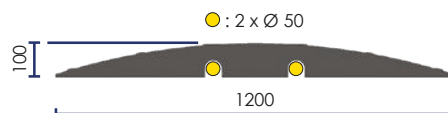

ZEBRA 65 / 100

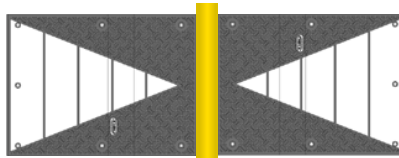



CPB

PASSE CÂBLE DE BUREAU ○ FLOOR CABLE COVER PROTECTOR DE CABLES ○ FUSSBODEN KABELBRÜCKE BODEN KABELBRÜCKE



SOUPLE ○ FLEXIBLE ○ FLEXIBLE ○ WEICH

Code	↔	kg
CPB 653	3 m	1,40
CPB 655	5 m	2,20
CPB 1023	3 m	3,00
CPB 1025	5 m	4,90

- CPB 653 / 655 ▶ 19 x 12
- CPB 1023 / 1025 ▶ 30 x 15



- En rouleau
- Chargement par le dessous
- Découpe facile au cutter
- Livré avec adhésif double face

- In roll
- Bottom loading
- Easy to cut with a cutter
- Supplied with double-sided tape

- En rollo
- Cargando desde abajo
- Fácil de cortar con un cutter
- Se suministra con adhesivo de doble cara

- In Rollen
- Ladung vom Unten
- Einfaches Schneiden mit dem Cutter
- Geliefert mit doppelseitigem Klebstoff

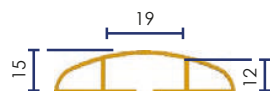

CPB 653 / 655

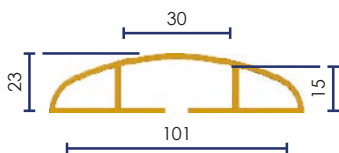

CPB 1023 / 1025



INCLUS
 INCLUDED
 INCLUIDO
 INKLUSIVE



RIGIDE ○ RIGID ○ RÍGIDO ○ STARR

Code	↔	kg
CPB 702	2 m	1,00
CPB 70 T		0,05
CPB 70 L		0,05

- ▶ 2 x (17 x 10)

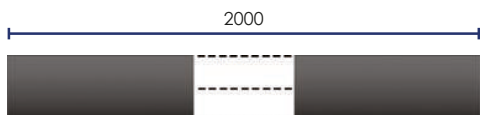
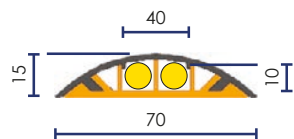

CPB 702



CPB 70 T



CPB 70 L



- Découpe possible à la longueur souhaitée
- Avec adhésif double face

- Can be cut to the desired length
- Supplied with double-sided tape

- Puede ser cortado a la longitud deseada
- Se suministra con adhesivo de doble cara

- Kann auf die Gewünschte Länge geschnitten werden
- Geliefert mit doppelseitigem Klebstoff

INCLUS
 INCLUDED
 INCLUIDO
 INKLUSIVE

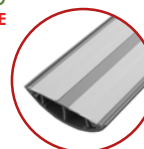



CP 5040

PASSE CÂBLE PIÉTON ◦ **PEDESTRIAN CABLE COVER**
PROTECTOR DE CABLES PEATONES ◦ **KABELBRÜCKE FÜR FUSSGÄNGERVERKEHR**

2 x Ø 20 + 5 x Ø 25

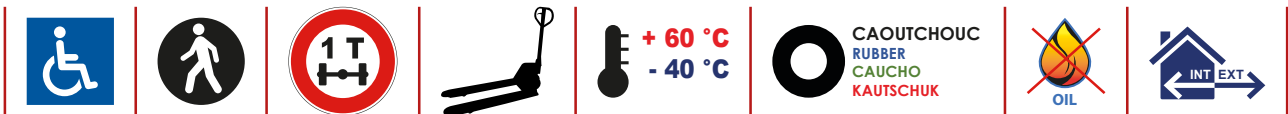

INSTALLATION TEMPORAIRE ◦ **TEMPORARY USE** ◦ **USO TEMPORARIO** ◦ **VORÜBERGEHENDE NUTZUNG**

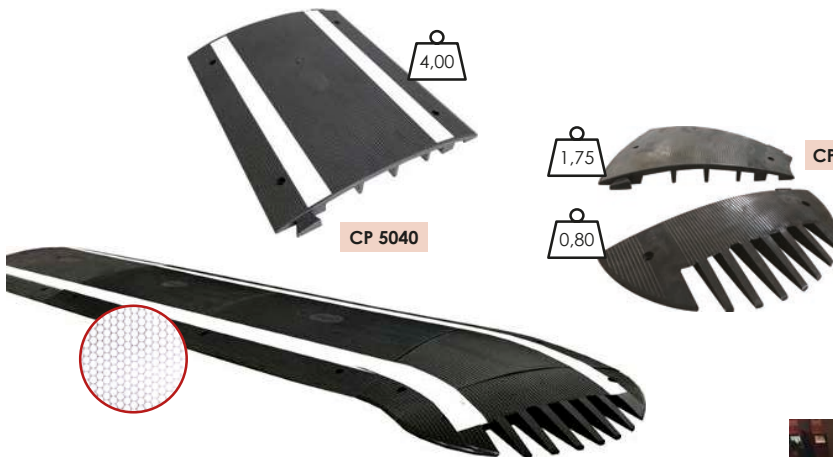
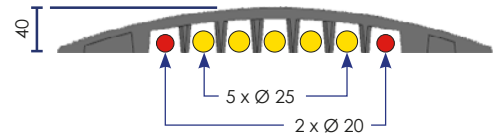
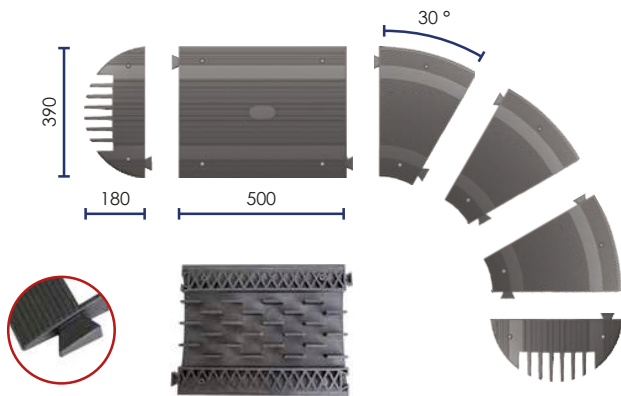

- Utilisation lors d'évènements en intérieur ou en extérieur dans les zones piétonnes (expositions, foires, etc.)
- Equipé d'emplacements pour mettre 2 bandes réfléchissantes classe 1 pour plus de sécurité
- To use at events both indoor and outdoor in pedestrian areas (exhibitions, fairs etc.)
- Equipped with space to put 2 class 1 reflective strips for more safety
- Para su uso en eventos tanto en el interior como en el exterior en zonas peatonales (exposiciones, ferias, etc.)
- Equipado con ranuras para poner 2 tiras reflectantes de clase 1 para mayor seguridad
- Einsatz bei Events im Innen- und Außenbereich in Fußgängerzonen (Ausstellungen, Messen, usw.)
- Ausgestattet mit Platzierung für 2 Reflektoren Streifen Klasse 1 für mehr Sicherheit

INCLUS
INCLUDED ◦ **INCLUIDO** ◦ **INKLUSIVE**



A collar ◦ To stick
 A pegar ◦ Zu kleben

OPTION
OPTIONAL ◦ **OPCIÓN** ◦ **OPTIONAL**



CP 5 FIX SB
 Ø 8 x 60



CP5 SPIKE SB
 Ø 6 x 300



CP 202 / 402

PASSE CÂBLE MODULAIRE ◦ **MODULAR CABLE PROTECTOR**
PROTECTOR DE CABLES MODULAR ◦ **KABELBRÜCKE MODULAR**

- CP 202 ▶ 2 x Ø 35
- CP 402 ▶ 4 x Ø 35



CAOUTCHOUC
RUBBER
CAUCHO
KAUTSCHUK

PVC Couverture
 Lid
 Tapa
 Deckel



INSTALLATION TEMPORAIRE ◦ **TEMPORARY USE** ◦ **USO TEMPORARIO** ◦ **VORÜBERGEHENDE NUTZUNG**

Code		
CP 202	4	9,0
CPR 202	3	9,5
CPE 202	2	4,0
CP 402	4	8,0
CPR 402	3	8,0
CPE 402	2	3,0

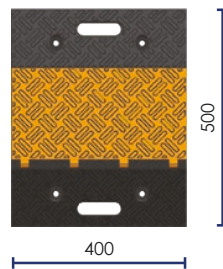
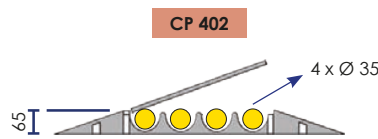
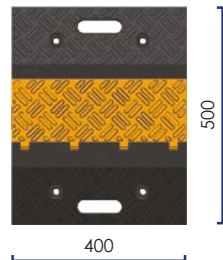
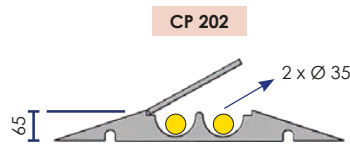

OPTION ◦ **OPTIONAL** ◦ **OPCIÓN** ◦ **OPTIONAL**



H de liaison pour connecter les éléments entre eux
 H links for connecting the elements together
 H de unión para conectar los elementos
 H Verbindung zum Verbinden von Bauteilen



SPIKES
 Ø 12 x 300



FIX 4 SB
 Ø 12 x 130



RQ GLUE



CPK 800 / 1100

PASSE CÂBLE TRANSPORTABLE PLIANT

FOLDABLE CABLE PROTECTOR

PROTECTOR DE CABLES PLEGABLE ◦ KABELBRÜCKE TRAGBAR/FALTBAR

● CPK 800 ▶ 2 x Ø 80

● CPK 1100 ▶ 2 x Ø 110



CAOUTCHOUC VULCANISÉ
VULCANIZED RUBBER
CAUCHO VULCANIZADO
VULKANISIERTEM KAUSCHUK



Couvercle
Lid
Tapa
Deckel



INSTALLATION TEMPORAIRE ◦ TEMPORARY USE ◦ USO TEMPORARIO ◦ VORÜBERGEHENDE NUTZUNG

Code			
CPK 800	300 x 190 x 425	850 x 300 x 90	18,40
CPK 1100	300 x 240 x 475	950 x 300 x 120	25,00

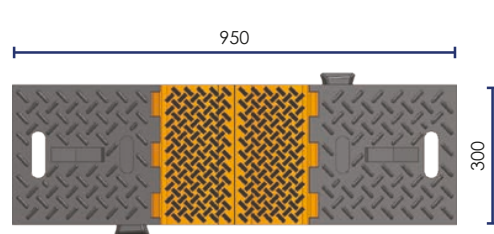
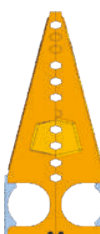
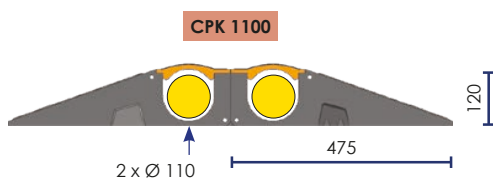
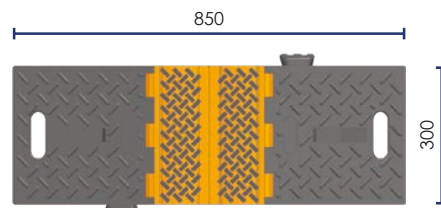
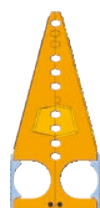
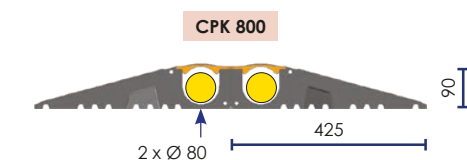

OPTION
OPTIONAL ◦ OPCIÓN ◦ OPTIONAL

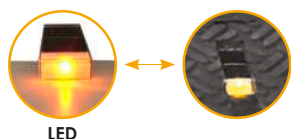

LED



CP 1000 SÉRIE

PASSE CÂBLE ◦ CABLE BRIDGE ◦ PROTECTOR DE CABLES ◦ KABELBRÜCKE



CAOUTCHOUC
RUBBER
CAUCHO
KAUSCHUK



Couvercle
Lid
Tapa
Deckel



INSTALLATION TEMPORAIRE
TEMPORARY USE
USO TEMPORARIO
VORÜBERGEHENDE NUTZUNG

CP 1081

2 x (38 x 35)

Code	kg
CP 1081	9,0
CPR 1081	2,0
CPE 1081	1,0
CPS 1081	2,7

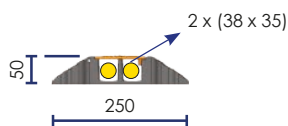
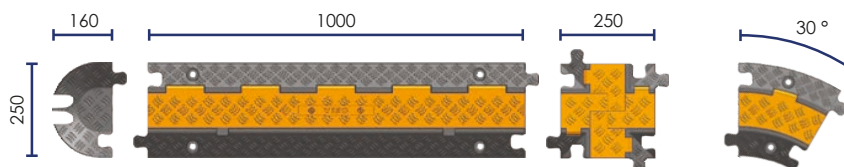

CP 1002

5 x (34 x 34)

Code	kg
CP 1002	17,2
CPR 1002	5,0
CPE 1002	3,0
CPS 1002	10

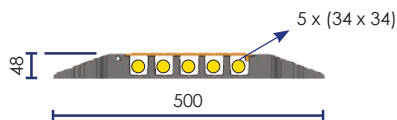
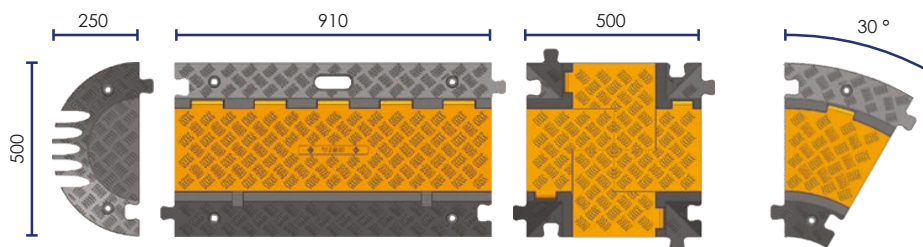

Poignée
Handle
Asa
Handgriff

Trous de fixation
Fixation holes
Agujeros de fijación
Befestigungslöcher

Assemblage
Assembling
Montaje
Montage

Fermeture capot
Lid closing
Cierre tapa
Deckel Verschlussung



- ▶ CP 1002
- ▶ CP 1031
- ▶ CP 1071

OPTION ◦ OPTIONAL ◦ OPCIÓN ◦ OPTIONAL



SPIKE 4 SB
Ø 12 x 300



FIX 1 SB
Ø 12 x 130



RQ GLUE



CP 1000 SÉRIE

PASSE CÂBLE ◦ CABLE BRIDGE ◦ PROTECTOR DE CABLES ◦ KABELBRÜCKE



CAOUTCHOUC
RUBBER
CAUCHO
KAUTSCHUK



Couvercle
Lid
Tapa
Deckel



INSTALLATION TEMPORAIRE
TEMPORARY USE
USO TEMPORARIO
VORÜBERGEHENDE NUTZUNG

CP 1031

3 x (58 x 52)

Code	kg
CP 1031	16,8
CPR 1031	4,6
CPE 1031	3,5
CPS 1031	13,0

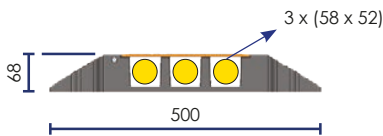
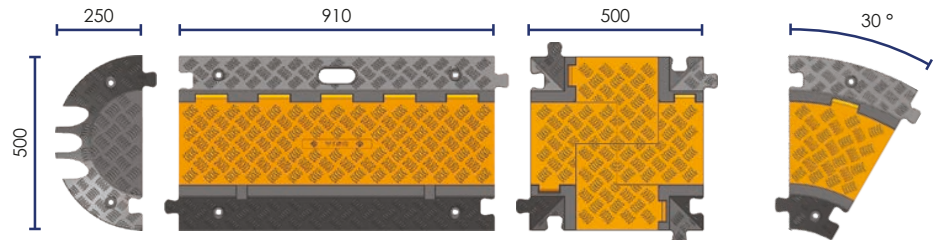

CP 1071

3 x (65 x 65)

Code	kg
CP 1071	23,0
CPR 1071	6,8
CPE 1071	4,5
CPS 1071	12,0

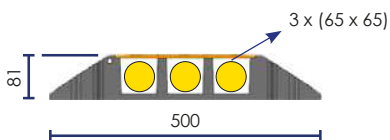
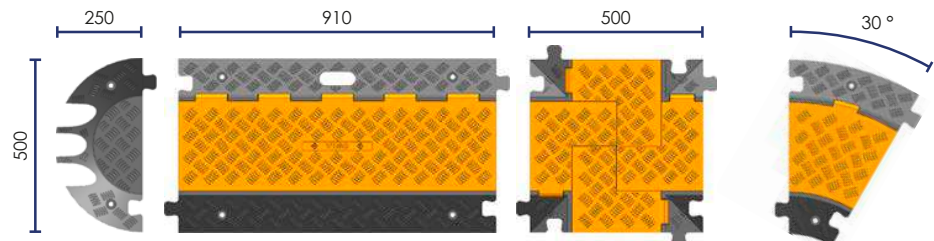

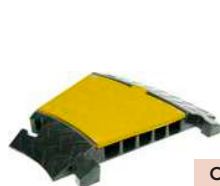

OPTION ◦ OPTIONAL ◦ OPCIÓN ◦ OPTIONAL





CPO

PASSE CÂBLE ET TUYAUX POIDS LOURD
HOSE AND CABLE BRIDGE
PROTECTOR DE CABLE Y MANGUERA
KABELBRÜCKE UND SCHLÄUCHE FÜR LKW

-  CPO 600 ▶ 2 x (75 x 80)
-  CPO 850 ▶ 2 x (95 x 90)
-  CPO 1000 ▶ 2 x (135 x 120)

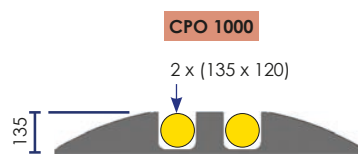
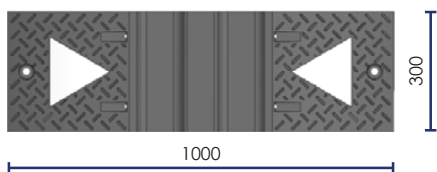
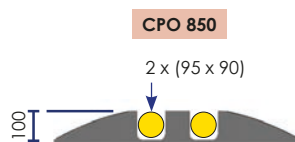
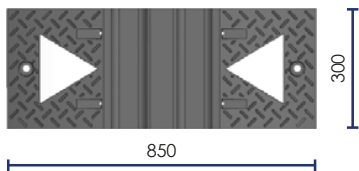
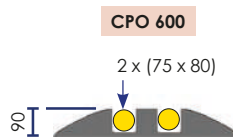
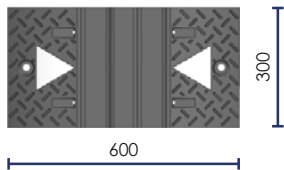

INCLUS ◦ INCLUDED ◦ INCLUIDO ◦ INKLUSIVE



x 4

OPTION ◦ OPTIONAL ◦ OPCIÓN ◦ OPTIONAL



GEY 1 SB

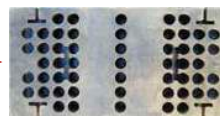

SPIKES
Ø 12 x 300



FIX 1 SB
Ø 12 x 130



RQ GLUE



PASSE CÂBLE ET TUYAUX POIDS LOURD

HOSE AND CABLE BRIDGE

PROTECTOR DE CABLE Y MANGUERA

LKW KABELBRÜCKE FÜR KABEL UND SCHLÄUCHE

- CP 500 ▶ 2 x Ø 50
- CP 800 ▶ 2 x Ø 80
- CP 1200 ▶ 1 x Ø 120

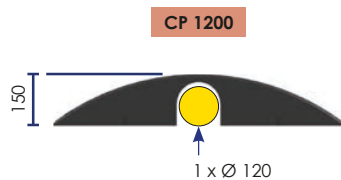
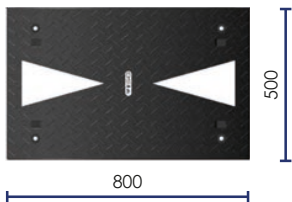
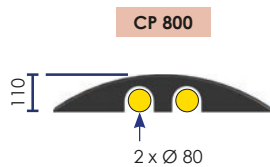
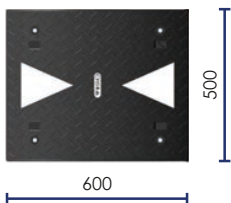
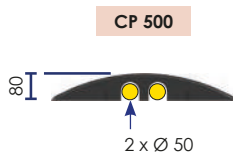
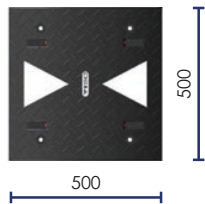

INCLUS ◦ INCLUDED ◦ INCLUIDO ◦ INKLUSIVE



x 4

OPTION ◦ OPTIONAL ◦ OPCIÓN ◦ OPTIONAL



GEY 1 SB

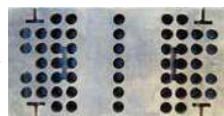

SPIKE 4 SB
Ø 12 x 300



FIX 4 SB
Ø 12 x 130



RQ GLUE

WP 100 / 170

WP 240

PASSE CÂBLE CHANTIER ◦ **WORKSITE CABLE PROTECTOR**
PROTECTOR DE CABLES PARA OBRAS ◦ **KABELBRÜCKE FÜR BAUSTELLE**

-  WP 100 ▶ 1 x Ø 20
-  WP 170 ▶ 1 x Ø 40
-  WP 240 ▶ 1 x Ø 60



CAOUTCHOUC VULCANISÉ
VULCANIZED RUBBER
CAUCHO VULCANIZADO
VULKANISIERTEM KAUSCHUK



INSTALLATION TEMPORAIRE ◦ **TEMPORARY USE** ◦ **USO TEMPORARIO** ◦ **VORÜBERGEHENDE NUTZUNG**

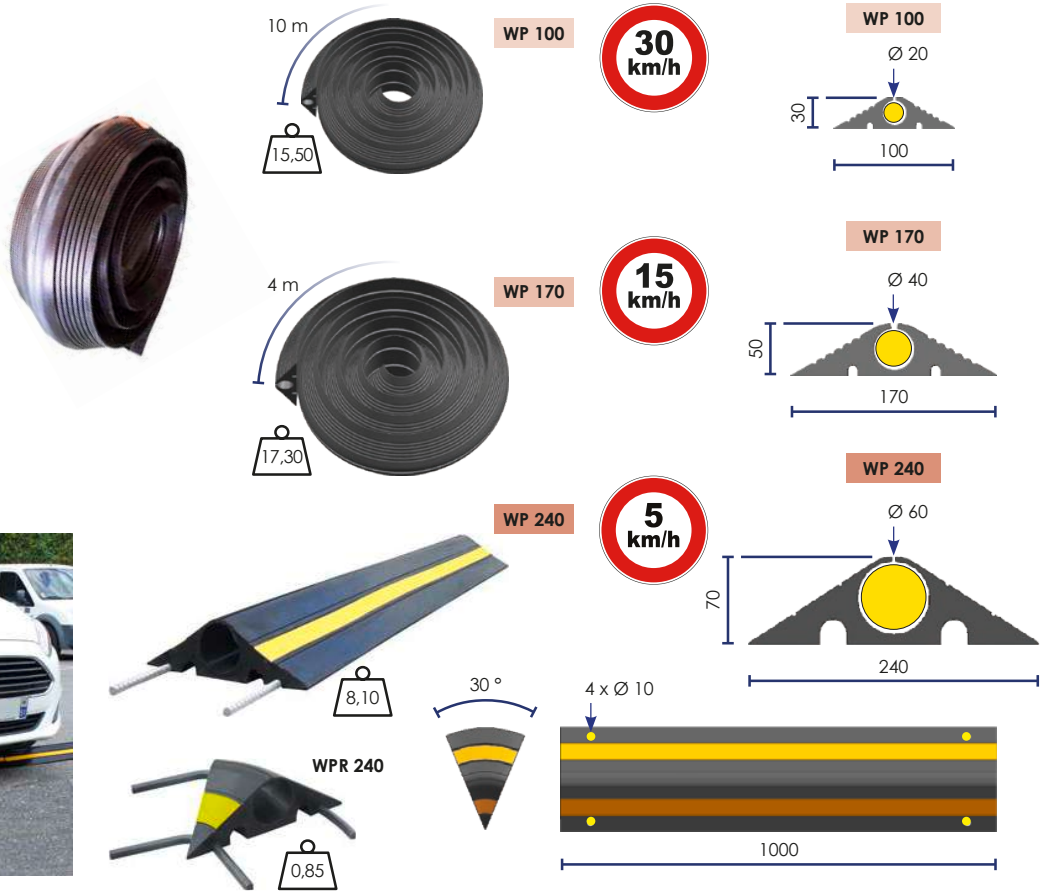

INCLUS ◦ **INCLUDED** ◦ **INCLUIDO** ◦ **INKLUSIVE**

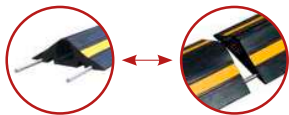

2 liaisons ◦ 2 links
 2 Elementos de unión
 2 Verbindungen
WP 240

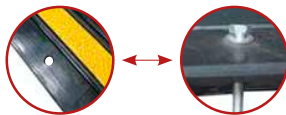

Trous de fixation ◦ Fixation holes
 Agujeros de fijación
 Befestigungslöcher
WP 240

OPTION ◦ **OPTIONAL** ◦ **OPCIÓN** ◦ **OPTIONAL**



SPIKE WP 244 SB
WP 240



FIX WP 244 SB
WP 240



RQ GLUE



PASSE CÂBLE GRANDE LONGUEUR ◦ EXTRA LONG CABLE BRIDGE
PROTECTOR DE CABLE EXTRA LARGO ◦ KABELBRÜCKE MIT GROSSER LÄNGER

● 1 x Ø 45 + 2 x Ø 20

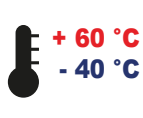

CP 450 JA



x 4 trous de fixation
 Fixation holes
 Agujeros de fijación
 Befestigungslöcher

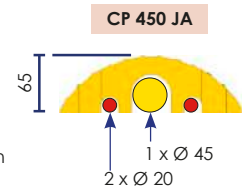

CP 450 JA

OPTION ◦ OPTIONAL ◦ OPCIÓN ◦ OPTIONAL



SPIKE 4 SB
 Ø 12 x 300



FIX 4 SB
 Ø 12 x 130



RQ GLUE



CPE 450 JA

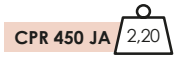
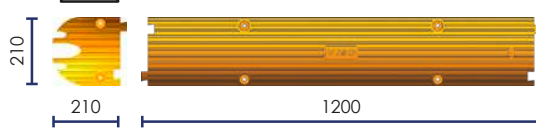

CPR 450 JA

PASSE CÂBLE TRAVERSÉE DE ROUTE ◦ ROAD CROSSING CABLE BRIDGE
PROTECTOR DE CABLES PARA CARRETERA ◦ KABELBRÜCKE FÜR STRASSE ÜBERQUERUNG

● 2 x Ø 50

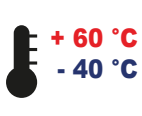

SCUP 100 N



SAFETY 100 NJ

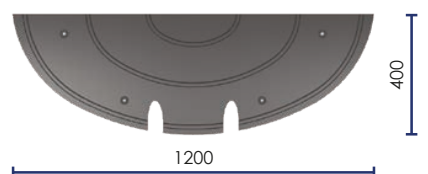
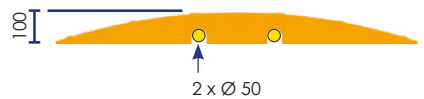

INCLUS ◦ INCLUDED
 INCLUIDO ◦ INKLUSIVE



x 2



x 4 trous de fixation
 Fixation holes
 Agujeros de fijación
 Befestigungslöcher

OPTION ◦ OPTIONAL ◦ OPCIÓN ◦ OPTIONAL



SPIKE 4 SB
 Ø 12 x 300



FSAFE 4 SB
 Ø 12 x 120



RQ GLUE



ZEBRA 65



ZEBRA 100

PASSE CÂBLE TRAVERSÉE DE ROUTE ◦ **ROAD CROSSING CABLE PROTECTOR**
PROTECTOR DE CABLES PARA CARRETERA ◦ **KABELBRÜCKE FÜR STRASSE ÜBERQUERUNG**

ZEBRA 65

0 65 mm



CAOUTCHOUC VULCANISÉ
 VULCANIZED RUBBER
 CAUCHO VULCANIZADO
 VULKANISIERTEM KAUSCHUK



Code	Ø Câble	Largeur route ◦ Road width Ancho de carretera ◦ Breite	kg
H 65 mm - Rouge ◦ Red ◦ Rojo ◦ Rot			
CP 2265	65	2,16	264
CP 2765		2,70	330
CP 3265		3,24	396
CP 3865		3,78	462
CP 4365		4,32	528
CP 4865		4,86	594
CP 5465		5,40	660
CP 5965		5,94	726

◐ Ø 65 – 80

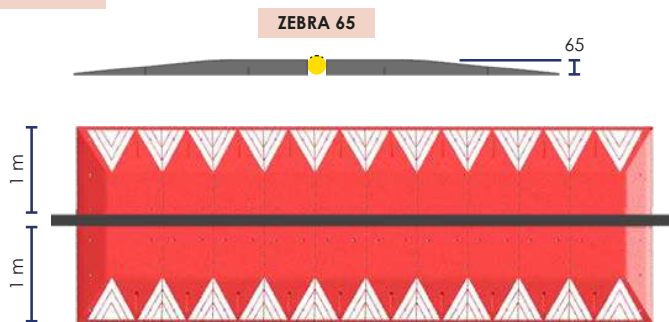

Noir : nous consulter. ◦ Black : ask us. ◦ Negro : consultarnos. ◦ Schwarz : Kontaktieren Sie uns.

ZEBRA 100

0 100 mm



CAOUTCHOUC VULCANISÉ
 VULCANIZED RUBBER
 CAUCHO VULCANIZADO
 VULKANISIERTEM KAUSCHUK



Code	Ø Câble	Largeur route ◦ Road width Ancho de carretera ◦ Breite	kg
H 100 mm - Noir ◦ Black ◦ Negro ◦ Schwarz			
CP 22100	100	2,25	375
CP 30100		3,00	500
CP 38100		3,75	625
CP 45100		4,50	750
CP 53100		5,25	875
CP 60100		6,00	1000

◐ Ø 100 – 120

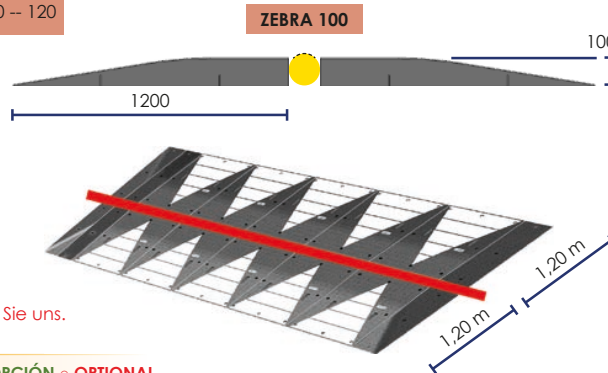

Rouge : nous consulter. ◦ Red : ask us. ◦ Rojo : consultarnos. ◦ Rot : Kontaktieren Sie uns.

INCLUS ◦ INCLUDED ◦ INCLUIDO ◦ INKLUSIVE



OPTION ◦ OPTIONAL ◦ OPCIÓN ◦ OPTIONAL

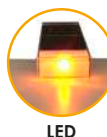





SSC 310 / 370



CSL 700

CÔNE DE SIGNALISATION PLIANT

FOLDABLE REFLECTIVE CONE ◦ CONO PLEGABLE CON LUZ ◦ FALTLITKEGEL



2 x LR03*



1 x CR2032*



Classe 2

* Piles non fournies ◦ Batteries not supplied
Baterías no incluidas ◦ Batterien nicht enthalten

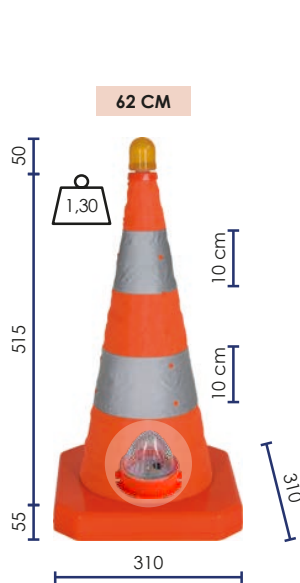

SSC 310

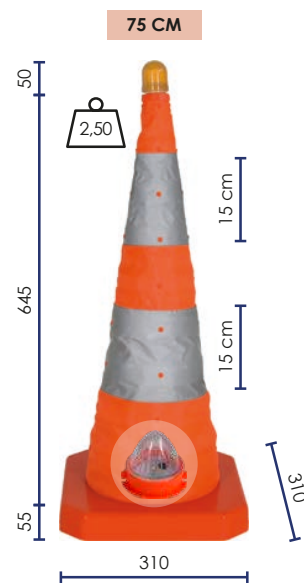

SSC 370

BALISE DE RUE

BLACK CUSTOMIZABLE CONE ◦ BALIZA ◦ STRASSEN LEITBAKE



Classe 1
Class 1
Clase 1
Klasse 1



Réfléchissant
Reflective
Reflectante
Reflektierende

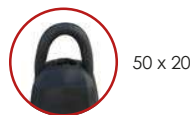

50 x 20



Personnalisation : mini 100
Customization mini 100
Personalización mini 100
Personalisierung : Mini 100

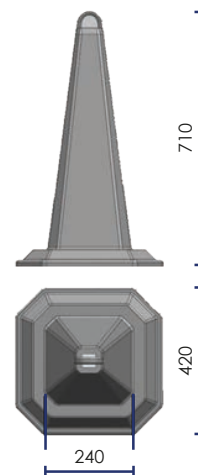



CÔNE RÉFLÉCHISSANT CLASSE 1

TRAFFIC CONE ◦ CONO DE SEÑALIZACIÓN ◦ REFLEKTIERENDER LEITKEGEL



Bandes réfléchissantes classe 1
Reflective tape class 1
Bandas reflectantes clase 1
Reflektierende Streifen Klasse 1



CSC 301 : Ø 45 mm
CSC 501 : Ø 45 mm
CSC 751 : Ø 31 mm

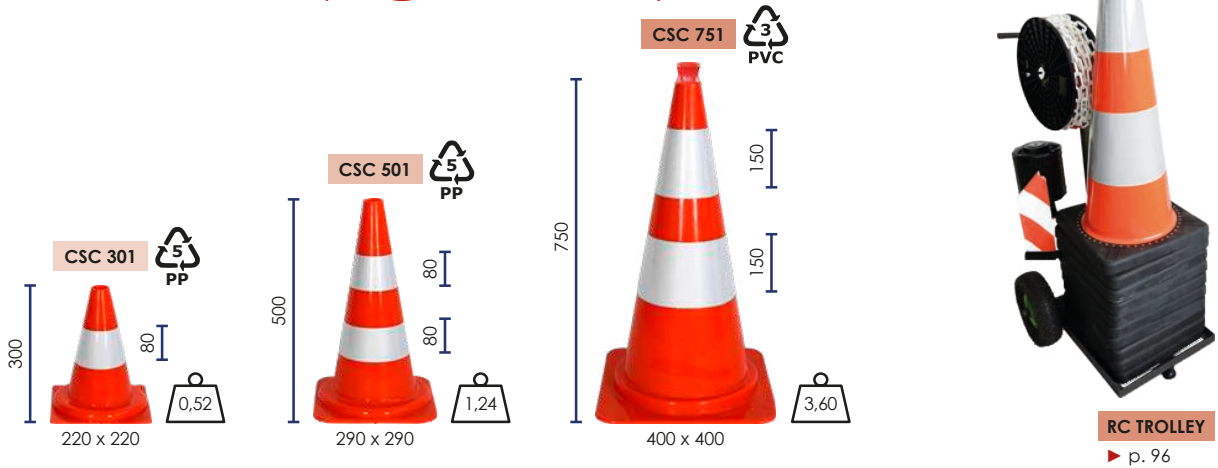

CÔNE LESTÉ CLASSE 2. EN 13422

HEAVY DUTY CONE ◦ CONO CON BASE CAUCHO ◦ LEITKEGEL - STANDFUSS SCHWER



Base
Base
Base
Standfuß

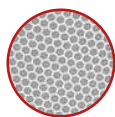

Bandes réfléchissantes classe 2
Reflective tape class 2
Bandas reflectantes clase 2
Reflektierende Streifen Klasse 2



300 m

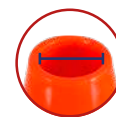

RC 300 : Ø 28 mm
RC 500 : Ø 30 mm
RC 752 : Ø 39 mm
RC 1000 : Ø 39 mm

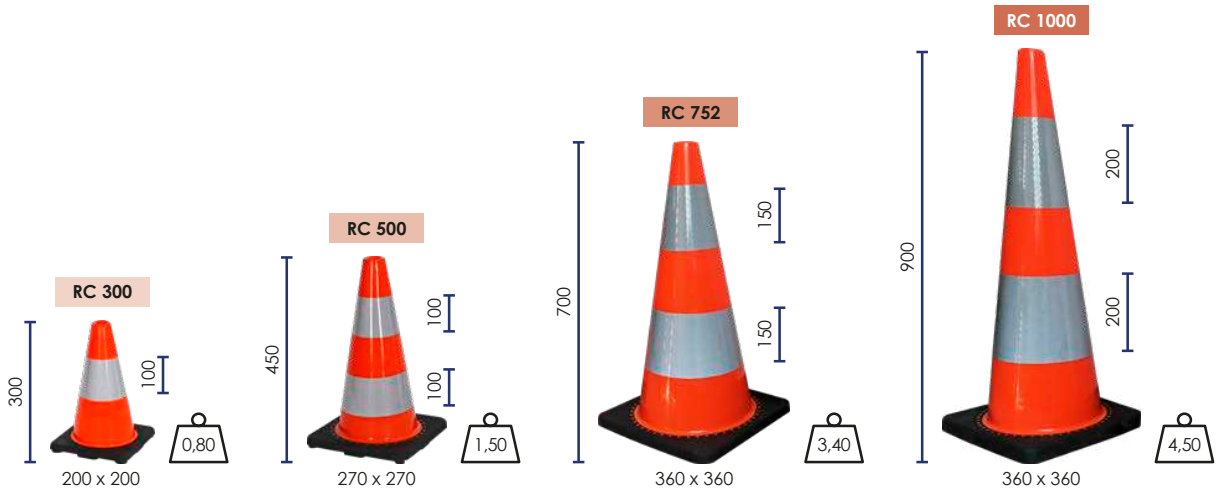

CÔNE AVEC SANGLE ◦ CONE WITH RETRACTABLE BELT ◦ CONO CON ENROLLADOR DE

HAUTEUR ◦ HEIGHT ◦ ALTURA ◦ HÖHE



70 CM

90 CM

COULEUR ◦ COLOR ◦ COLOR ◦ FARBE



Choix des couleurs uniquement pour les cônes 90 cm
Color's choice only for 90 cm cones
Elección de colores solamente para conos de 90 cm
Farbwahl nur für Leitkegel 90 cm



Base
Base
Base
Standfuß



Ø 39 mm



PVC souple
Flexible PVC
PVC flexible
Flexibel PVC



Base caoutchouc
360 x 360 mm
Rubber base
Base de caucho
Gummi Standfuß

Réfléchissant
Reflective
Reflexivo
Reflektierend

CLASSE 2. EN 13422



Base caoutchouc
Rubber base
Base de caucho
Gummi Standfuß



Base vide à lester
550 x 550 mm

Empty base to be loaded

Base de lastre vacía

Leerer Sockel zum beschweren

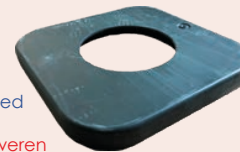

3. COLORIS DE SANGLE ◦ BELT COLOR ◦ COLOR DE CINTA ◦ FARBE DES GURTES

2 M X 50 MM
4 M X 50 MM



STOP

ISSUE DE SECOURS

10 M X 50 MM
4 M X 100 MM
10 M X 100 MM



▲ Sangle personnalisée (sauf 10 m), nous consulter.
Customized belt (except 10 m), consult us.
Cinta personalizada (salvo 10 m), consultarnos.
Gurt Personalisierung (außer 10 m), uns konsultieren.



ENROULEURS

RETRACTABLE BELT BARRIER ◦ ENROLLADOR DE CINTA ◦ ABSPERRGURT

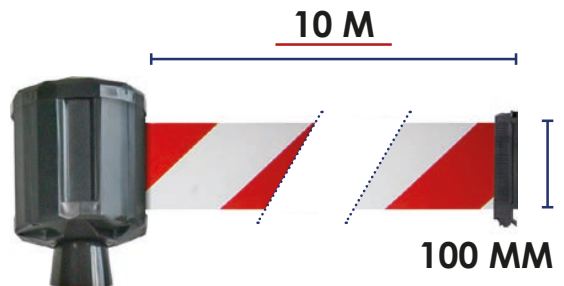
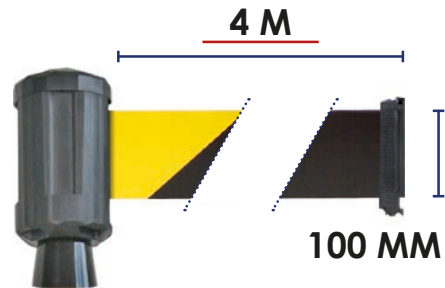
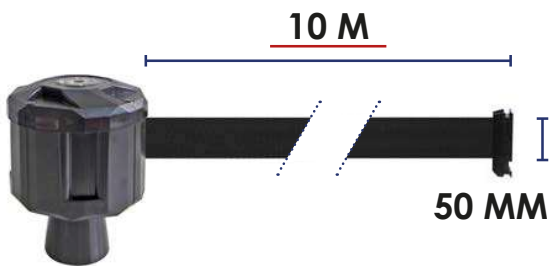
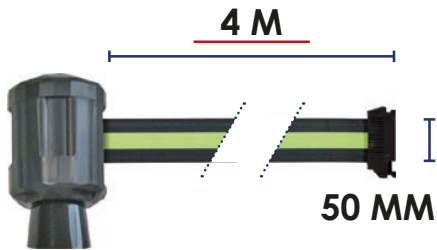
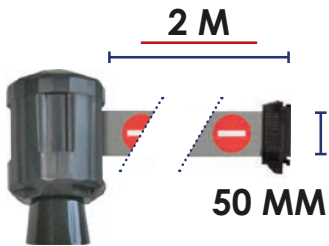

4. OPTIONS ◦ OPTIONS ◦ OPCIONES ◦ OPTIONEN

BOITIER RÉCEPTEUR VIDE

EMPTY RECEIVER BOX

CAJA RECEPTORA SIN CINTA

LEERES EMPFANGSBOX



PANNEAUX A3 ET A4

A3 AND A4 PANELS

PANELES A3 Y A4

PANEELE A3 UND A4

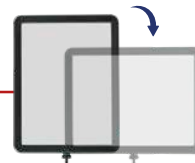

STICKERS ◦ STICKERS ◦ ADHESIVOS ◦ AUFKLEBER

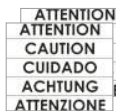

CÔNES PVC - BASE CAOUTCHOUC ○ PVC CONES - RUBBER BASE ○ CONOS DE PVC

CLASSE 2. EN 13422



Cône ○ Cone
Cono ○ Leitkegel

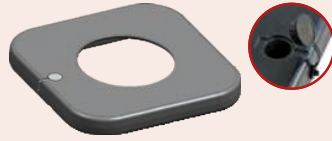

Base vide à lester
550 x 550 mm
Empty base to be loaded
Base de lastre vacía
Leerer Standfuß zu beschweren



Adaptateur
Connector
Adaptador
Adapter



Enrouleur
Retractable barrier
Enrollador de cinta
Abspergurt

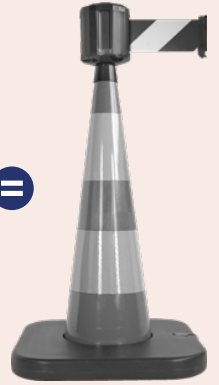

85 CM

Longueur sangle
Belt length
Largo de cinta
Gürtlänge



2 M

RCX72RE

RCX72RB

RCX72ENT

50 MM

Largeur sangle ○ Belt width ○ Ancho de cinta ○ Gürtbreite

4 M

RCX74RE

RCX74RB

RCX74ENT

10 M

RCX105RE

RCX105RB

90 CM

4 M

RCX741RE

RCX741RB

100 MM

10 M

RCX110RE

RCX110RB

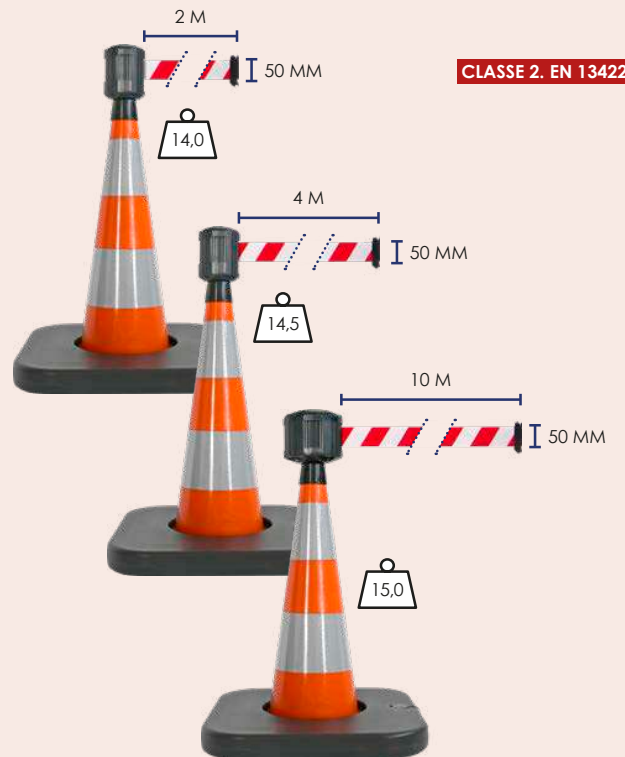

CLASSE 2. EN 13422

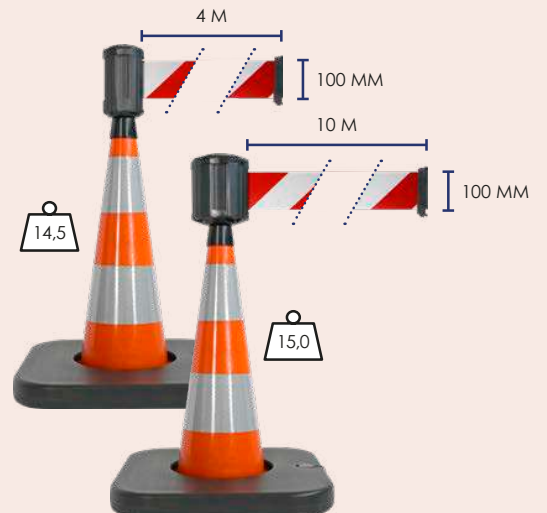



105 CM



RCX102RB

RCX102ENT

RCX102NJ

RCX102BYB

RCX102DAN

RCX102BBR

RCX102BU

RCX102VE



RCX104RB

RCX104ENT

RCX104NJ

RCX104BYB

RCX104DAN

RCX104BBR

RCX104BU

RCX104VE



RCX1050RB

RCX1050NJ

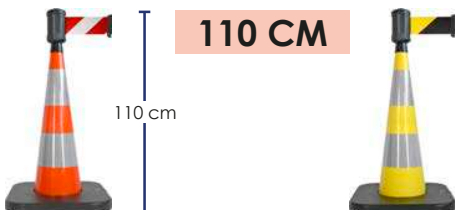

110 CM

RCX1041RB

RCX1041NJ



RCX1100RB

RCX1100NJ





BOITIER RÉCEPTEUR VIDE UNIVERSEL*

EMPTY RECEIVER BOX ◦ CAJA RECEPTORA SIN CINTA ◦ LEERE EMPFANGSBOX

Code	Pour ◦ For Para ◦ Für
RCBOX VID 24	RCX 2 / RCX 4
RCBOX VID 410	RCX 410
RCBOX VID 105	RCX 1050
RCBOX VID 110	RCX 1100



Peut recevoir jusqu'à 3 sangles ◦ Can receive up to 3 belts
Puede recibir hasta 3 cintas ◦ Kann bis zu 3 Gurtes aufnehmen



ENROULEUR UNIVERSEL*

UNIVERSAL RETRACTABLE BARRIER ◦ ENROLLADOR DE CINTA ◦ UNIVERSELL ABSPERRGURT

2 M X 50 MM

RCBOXBK2	●	RCBOXRB2	◐
RCBOXRE2	●	RCBOXNJ2	◑
RCBOXBU2	●	RCBOXBY2	◒
RCBOXGR2	●	RCBOXENT2	◓
RCBOXJA2	●	RCBOXDAN2	◔
RCBOXVE2	●	RCBOXBBR2	◕
RCBOXSTOP2	STOP ◐ STOP	RCBOXSECOURS2	ISSUE DE SECOURS

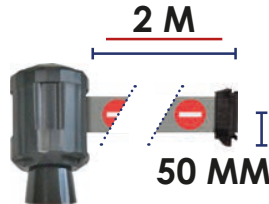

RCUNIVERSAL

Adaptateur
Connector
Adaptador
Adapter



4 M X 50 MM

RCBOXBK4	●	RCBOXRB4	◐
RCBOXRE4	●	RCBOXNJ4	◑
RCBOXBU4	●	RCBOXBY4	◒
RCBOXGR4	●	RCBOXENT4	◓
RCBOXJA4	●	RCBOXDAN4	◔
RCBOXVE4	●	RCBOXBBR4	◕
RCBOXSTOP2	STOP ◐ STOP	RCBOXSECOURS2	ISSUE DE SECOURS

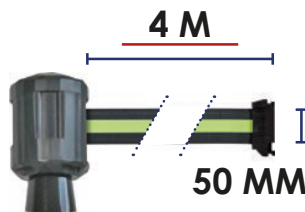

4 M X 100 MM

RCBOXBK410	●
RCBOXRE410	●
RCBOXRB410	◐
RCBOXNJ410	◑

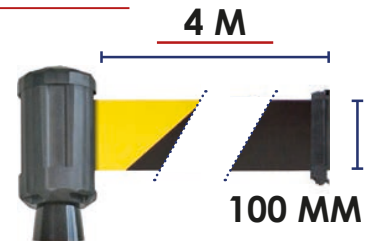

10 M X 50 MM

RCBOXBK105	●
RCBOXRE105	●
RCBOXRB105	◐
RCBOXNJ105	◑

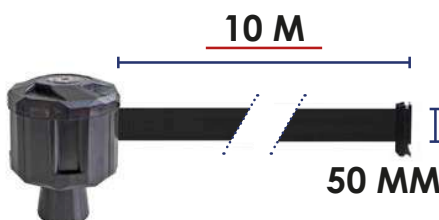

10 M X 100 MM

RCBOXBK110	●
RCBOXRE110	●
RCBOXRB110	◐
RCBOXNJ110	◑

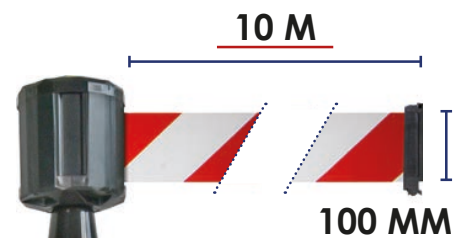

* Compatible tous cônes ◦ Compatible with all cones ◦ Compatible con todos los conos ◦ Kompatibel mit allen Kegeln

Récepteur mural ▶ p. 222 ◦ Wall receiver ▶ p. 222 ◦ Receptor mural ▶ p. 222 ◦ Wandempfänger ▶ p. 222

AFFICHAGE ◦ SIGN BOARD ◦ PORTA CARTEL ◦ INFOTAFEL



Code
RCPNX A4
RCPNX A3

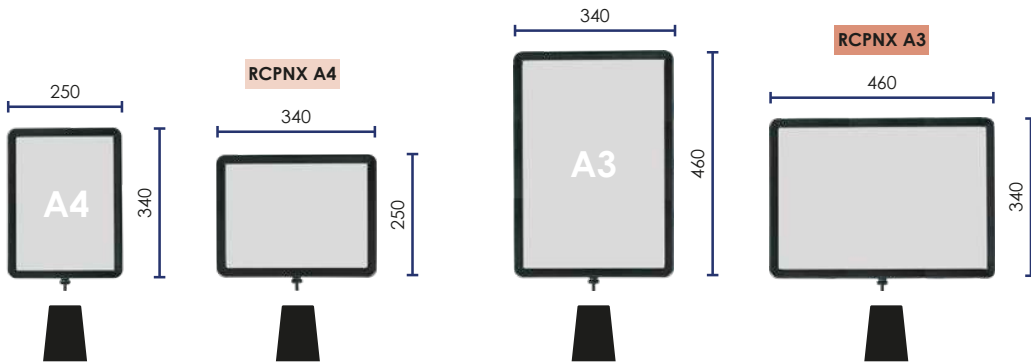
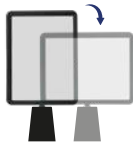

BASE ◦ BASES ◦ BASES ◦ STANDFUß

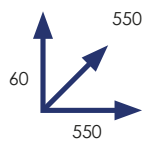

Base lestée béton
Concrete loaded base
Base lastrada con hormigón
Beton beschwertem standfuß



Base vide à lester
Empty base to be loaded
Base de lastre vacía
Leerer standfuß zum beschweren



RCBASE LO



RCBASE VD



STICKER ◦ STICKERS ◦ ADHESIVOS ◦ AUFKLEBER

Lot de 2 stickers 210 x 210 mm
Set of 2 stickers
Lote de 2 adhesivos
Set von 2 Stickern



STICKINTERDIT



STICKCHUTE



STICKNOPARK

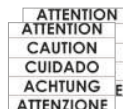

STICKTEXT1

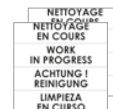

STICKTEXT2



STICKNOIPETON



STICKCHANTIER



STICKDANGER



STICELECT



STICKNOPASS



RC LAMPSOL 180

► RC 752 / 1000



FLASH 90

► RC 752 / 1000



RC 101 FLASH

► RC 752 / 1000



RC 101 FLASH x 1

RC 106 FLASH x 6

RC TROLLEY



10 / 20 Cônes suivant modèle ◦ 10 / 20 depending on the type ◦ 10 / 20 conos según modelo ◦ Leikegel nach Modell

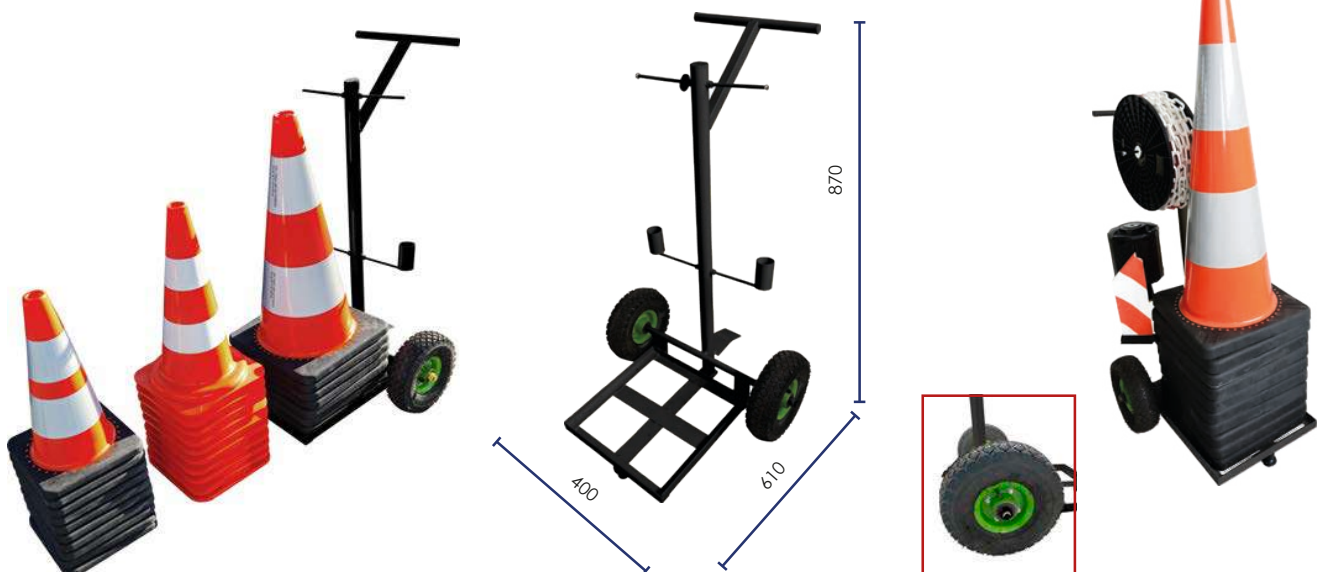

BARRES EXTENSIBLES ◦ EXPANDING BARRIERS ◦ BARRAS EXTENSIBLES ◦ TELESKOPSTANGE

Compatible tous cônes
Compatible with all cones ◦ Compatible con todos los conos ◦ Kompatibel mit allen Kegeln

Code	
RC BAR215 RB	
RC BAR215 NJ	
RC BAR215 BU	
RC BAR215 VE	



Bandes réfléchissantes classe 1
Reflective tape class 1
Bandas reflectantes clase 1
Reflektierende Streifen Klasse 1

Verrouillage à la longueur désirée
Blocking device at chosen length
Bloqueo a la longitud elegida
Sperrvorrichtung in gewählter Länge



BARRES ◦ BARRIERS ◦ BARRAS ◦ PLANKEN

Compatible tous cônes
Compatible with all cones ◦ Compatible con todos los conos ◦ Kompatibel mit allen Kegeln

EXTENSIBLES EXPANDABLE EXTENSIBLE TELESKOPISCH

Bandes réfléchissantes classe 1
Reflective tape class 1
Bandas reflectantes clase 1
Reflektierende Streifen Klasse 1

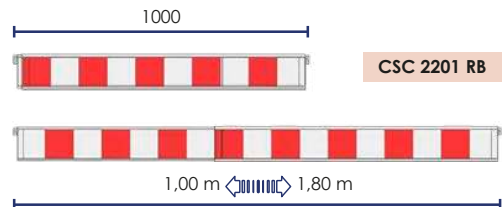
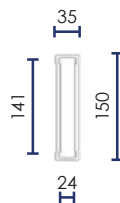
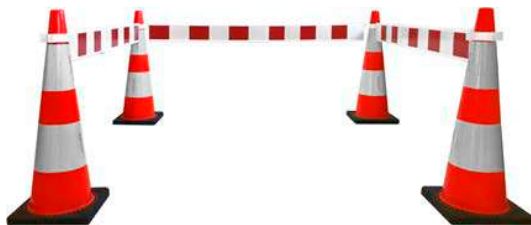

CHAÎNES ◦ CHAINS ◦ CADENAS ◦ KETTEN

Compatible tous cônes
Compatible with all cones ◦ Compatible con todos los conos ◦ Kompatibel mit allen Kegeln



Code		
CBR 801 SBS		25 m x Ø 8
CNJ 801 SBS		
CBB 801 SBS		
CBV 801 SBS		



Code
CS RING 5 SB





PRESSING

ROY
CHOCOLATIER

CLAVIER
TOUTES LES
SAISONS
CARTONNIERIE

CLAVIER
TOUTES LES
SAISONS
CARTONNIERIE



RAMPES

RAMPS ◦ RAMPAS ◦ BORDSTEIN-RAMPEN



+ 60 °C
- 40 °C

CAOUTCHOUC VULCANISÉ
VULCANIZED RUBBER
CAUCHO VULCANIZADO
VULKANISIERTEM KAUSCHUK



RR

Code	H	l	kg	
RR 35	35	300	6,50	4
RR 100	100	300	12,00	4
RR 150	150	360	19,00	4
RR 200	200	450	32,00	4
RRD 35	35	300	2,00	2
RRD 100	100	300	4,00	2
RRD 150	150	360	8,00	2
RRD 200	200	450	17,00	2

Code	Ø A	Ø B
RR / RRD 35	-	10
RR / RRD 100	25	30
RR / RRD 150	30	35
RR / RRD 200	35	40

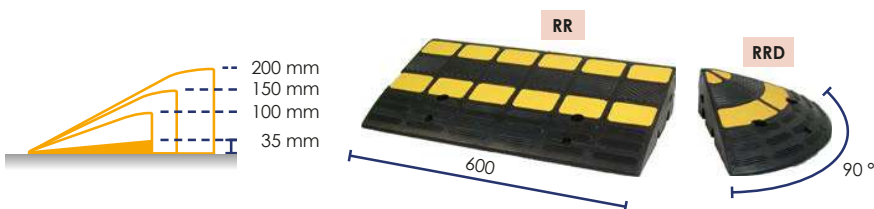
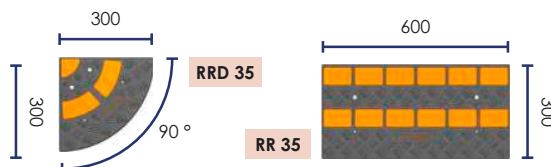
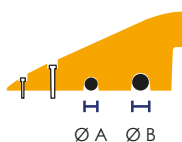

OPTION ◦ OPTIONAL ◦ OPCIÓN ◦ OPTIONAL



RR FIX 4 SB
2 x Ø 6
2 x Ø 10



RR SPIKE 4 SB
2 x (Ø 7 x 300)
2 x (Ø 10 x 300)



RQ GLUE

ZE

Code			kg
ZE 100 RAMP	6	7	55
ZE 100 END	3	5	23
ZE 25 G	3	3	17
ZE 25 D	3	3	17

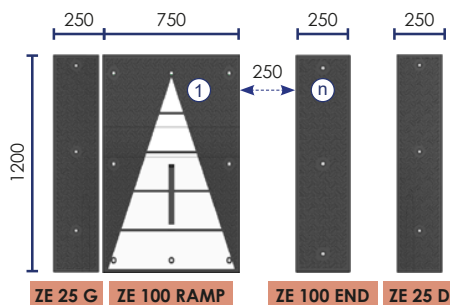

INCLUS ◦ INCLUDED ◦ INCLUIDO ◦ INKLUSIVE



FIX 1 SB
Ø 12 x 130

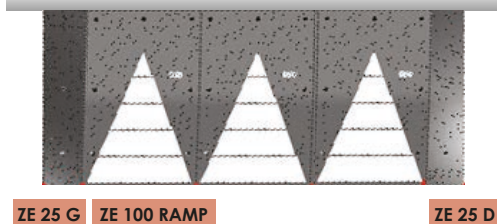

ZE 25 G ZE 100 RAMP

ZE 25 D



RR

PLAQUE DE CHAUSÉE

ROAD PLATE ◦ RAMPA PARA ZANJAS ◦ ÜBERFAHRPLATTE



CAOUTCHOUC VULCANISÉ
VULCANIZED RUBBER
CAUCHO VULCANIZADO
VULKANISIERTEM KAUSCHUK



Code		
RR 1400	1400 x 800 x 50	18
RR 1700	1700 x 1000 x 50	20
RR 2060	2000 x 600 x 50	23

Emboitable ◦ Expandable ◦ Encajable ◦ Dehnbare



Jonction
Junction
Junta
Verbindung



RR 1400

1000
maxi

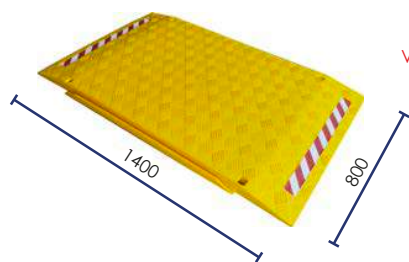

RR 1700

1000
maxi

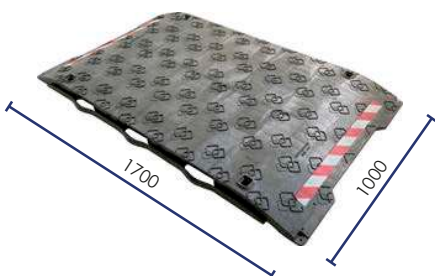

RR 2060

0,5 m	20000
0,7 m	10000
0,9 m	5000
1,2 m	1000

maxi

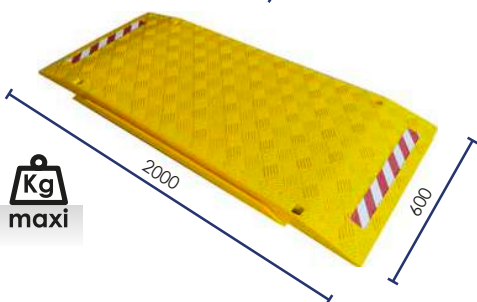

Patins anti-glisse
Non skid pad
Tapa antideslizante
Rutschfest



Renforts acier
Steel reinforcement
Refuerzos de acero
Stahlverstärkungen

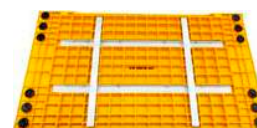

Poignée de transport
Transport handle
Asa de transporte
Handgriff



Trous de fixation
Fixation holes
Agujeros de fijación
Befestigungslöcher



Patins anti-glisse
Non skid pad
Tapa antideslizante
Rutschfest

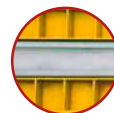

Renforts acier
Steel reinforcement
Refuerzos de acero
Stahlverstärkungen



OPTION ◦ OPTIONAL ◦ OPCIÓN ◦ OPTIONAL



RR 1401 ▶ RR 1400
RR 2001 ▶ RR 2060



RR 1701 ▶ RR 1700



RR 1400 M ▶ RR 1400
RR 2060 M ▶ RR 2060



RR 1400 F ▶ RR 1400
RR 2060 F ▶ RR 2060



PASS

PASSERELLE ◦ FOOTBRIDGE ◦ PASARELA ◦ BRÜCKE



Jonction
 Junction
 Junta
 Verbindung

Emboitable
 Expandable
 Encajable
 Dehnbare



740*
PASS 800



1460*
PASS 1600



2200*
PASS 2400



859*
PASS 1708



1859*
PASS 1718

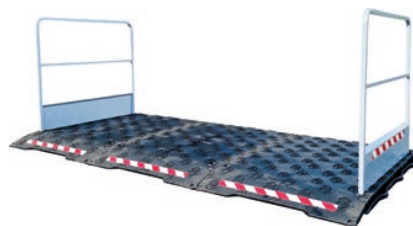

2859*
PASS 1728



Code	L	* mm	kg
PASS 800	1400	740	26,5
PASS 1600		1460	48,5
PASS 2400		2200	63,0
PASS 3200		2940	81,0
PASS 1708	1700	859	38,0
PASS 1718		1859	60,0
PASS 1728		2859	82,0
PASS 2010	2000	1030	55,0
PASS 2018		1630	84,0
PASS 2024		2230	107,0



1030*
PASS 2010



1630*
PASS 2018



kg	kg maxi
0,5 m	20000
0,7 m	10000
0,9 m	5000
1,2 m	1000

* Passage utile ◦ Useful width ◦ Ancho útil ◦ Nützliche Passage



COUVERTURE DE TRANCHÉES

TRENCH COVER PLATE ◦ PLACA CUBRE ZANJAS ◦ GRABENABDECKUNGEN



RR 1280

	kg maxi
1,1 m	350
0,9 m	500
0,7 m	600
0,5 m	700

kg
maxi



14



Renforts acier
Steel reinforcement
Refuerzos de acero
Stahlverstärkungen

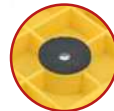

Patins anti-glisse
Non skid pad
Tapa antideslizante
Rutschfest

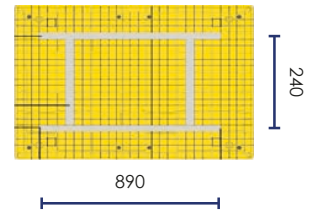
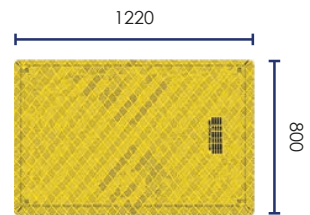

RR 1612

	kg maxi
1,1 m	350
0,9 m	500
0,7 m	600
0,5 m	700

kg
maxi

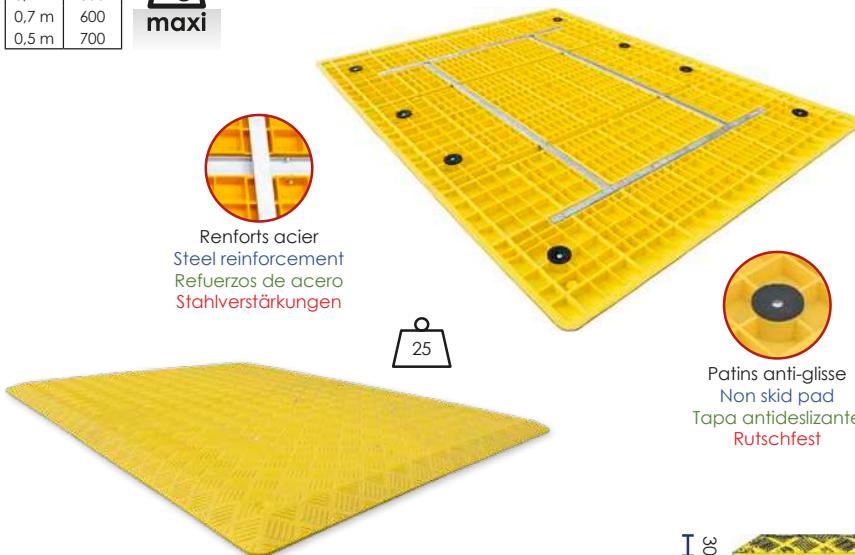

25



Renforts acier
Steel reinforcement
Refuerzos de acero
Stahlverstärkungen



Patins anti-glisse
Non skid pad
Tapa antideslizante
Rutschfest

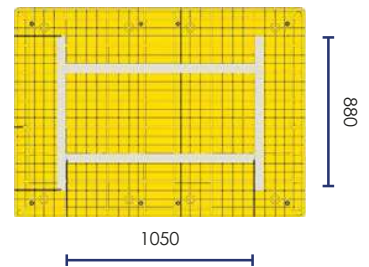
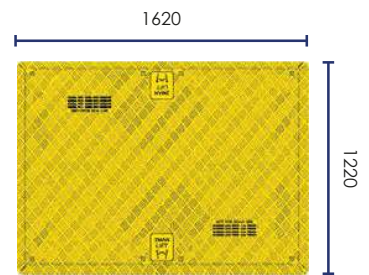



RAMP

ADJ 1100

RAMPE D'ACCÈS TRANSPORTABLE

TRANSPORTABLE ACCESS RAMP ◦ RAMPA DE ACCESO PORTÁTIL ◦ MOBILE RAMPEN

Code			
		kg maxi	kg
ADJ 1100	1120 (1010) x 750 x 160	300	9

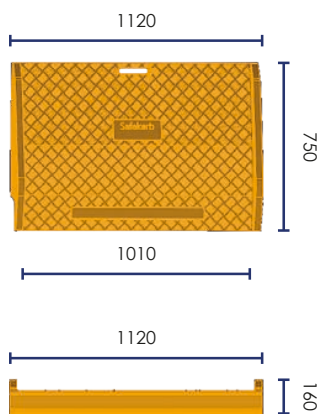

PLIANTES ◦ FOLDABLE ◦ PLEGABLE ◦ FALTBARE

Code			
		kg maxi	kg
RAMP 125	1220 x 710 x 50	300	9,2
RAMP 178	1830 x 710 x 50	300	13,8



Bavette ajustable
Adjustable plate
Placa ajustable
Einstellbarer Schaufel

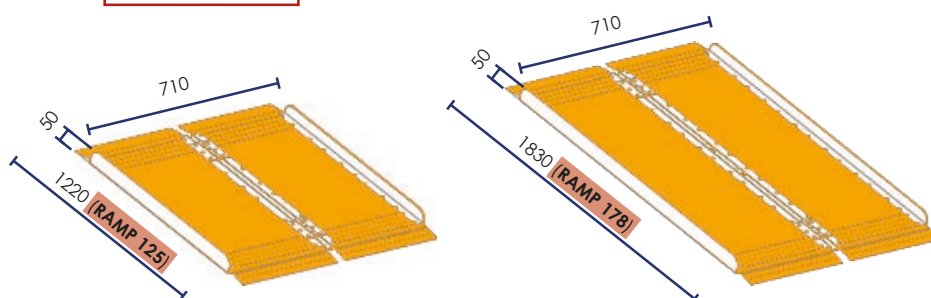



BALISAGE ◦ MARKING ◦ SEÑALIZACIÓN ◦ WARNMARKIERUNG



HAUTE VISIBILITÉ
HIGH VISIBILITY
ALTA VISIBILIDAD
HOHER SICHTBARKEIT

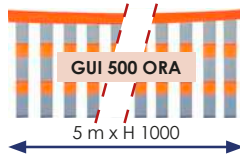

BARRIÈRE EXTENSIBLE ◦ EXPANDABLE BARRIER ◦ BARRERA EXTENSIBLE ◦ ABSPERR-SCHERENGITTER

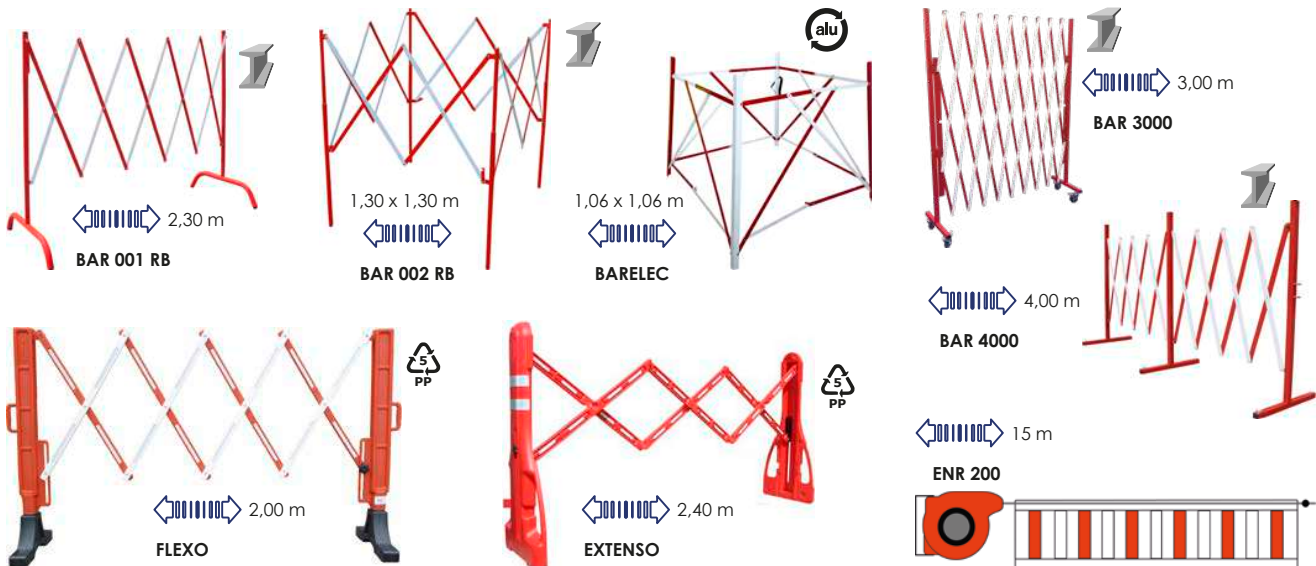

BARRIÈRES POLYPROPYLENE

POLYPROPYLENE BARRIERS ◦ BARRERAS DE POLIPROPILENO ◦ SPERRGITTER

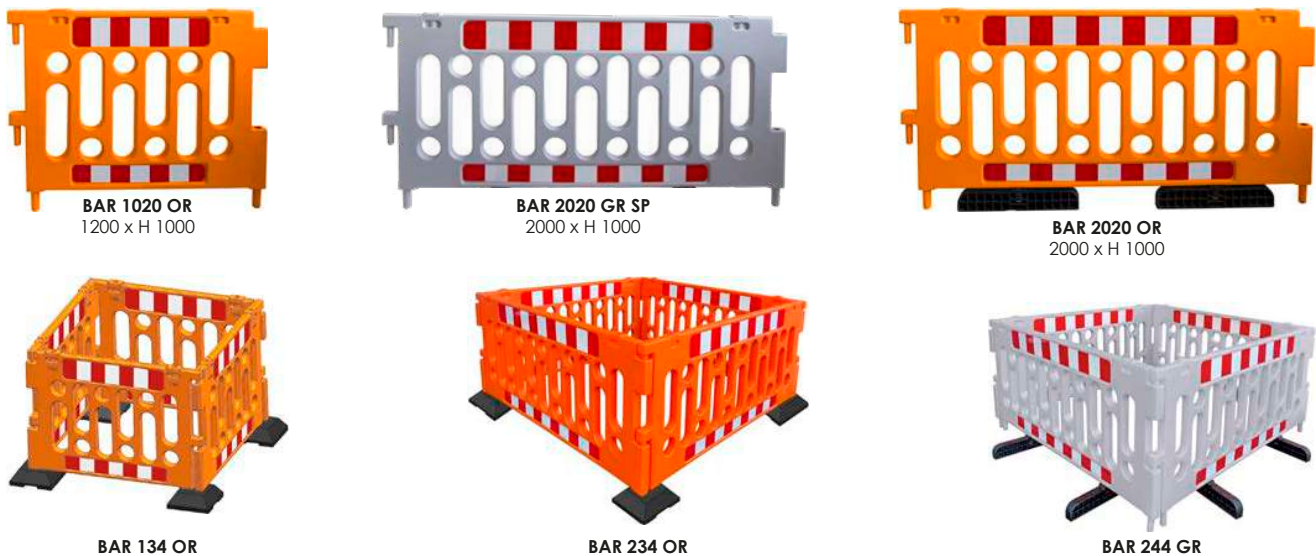



AK5 LED



CLASSE 1

CLASSE 2



TRIAK

PANNEAU SOLAIRE A LED

SOLAR LED TRAFFIC SIGN ◦ PANEL DE TRAFICO CON LED ◦ LEUCHTTAFELN



Informations techniques, voir page 35
 Technical specifications see page 35
 Datos técnicos ver página 35
 Technische Informationen, siehe Seite 35



AK5 LED



INCLUS ◦ INCLUDED ◦ INCLUIDO ◦ INKLUSIVE

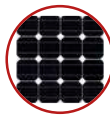

CLASSE 2



Ø 60 / 8 led Ø 5 mm

TRIPODE PLIABLE

FOLDABLE TRIPOD ◦ TRIPODE PLEGABLE ◦ DREIBEINIGEN FALTSIGNAL



TRIAK5 BL



TRIAK14 BL

Système de ressort parapluie
 Umbrella spring system
 Sistema de resorte tipo paraguas
 Regenschirm-Federsystem

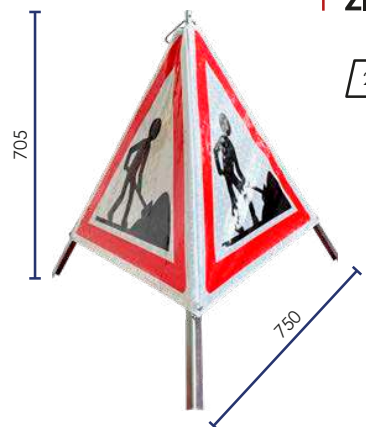

TRIAK5



TRIAK14



TRIGEO



TRIFAU

INCLUS ◦ INCLUDED ◦ INCLUIDO ◦ INKLUSIVE

Toile PP enduit PVC
 PP fabric and PVC coating
 Tela PP cubierto con PVC
 PVC beschichtete Polyestergerewebe



CLASSE 1

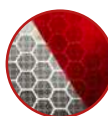

CLASSE 2



Sac de transport
 Transport bag
 Bolsa de transporte
 Transporttasche

OPTION
 OPTIONAL
 OPCIÓN
 OPTIONAL

Personnalisation
 Customization
 Personalización
 Personalisierung mini 50



BAR 03 RB

BALISAGE ◦ MARKING ◦ SEÑALIZACIÓN ◦ WARNMARKIERUNG

BARRIÈRE DE CHANTIER ◦ BARRIER ◦ BARRERA ◦ ABSPERRUNGEN

BAR 03 RB

Plaque personnalisable
Customizable plate
Placa personalizable
Personalisierbare Platte



minimum de commande : 5 ◦ MOQ = 5 pcs
Pedido mínimo : 5 ◦ Mindestbestellmenge: 5

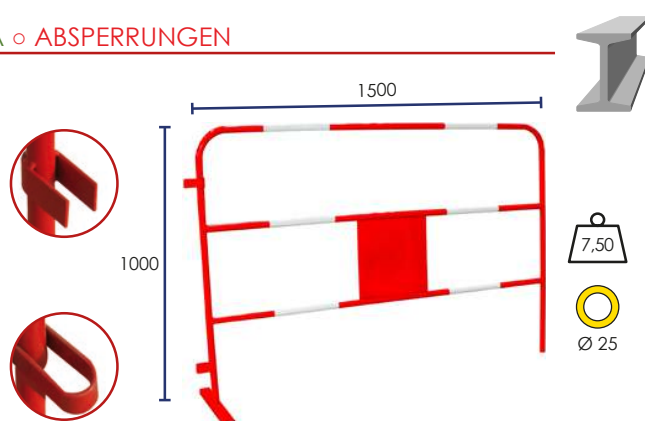

PIQUET ◦ REFLECTIVE POSTS ◦ POSTE REFLECTIVO ◦ LEITBAKE

Code	Face(s)	Classe	
ROAD 1011	1	1	x 10
ROAD 1021	2	1	
ROAD 1012	1	2	
ROAD 1022	2	2	

Angles arrondis
Rounded corners
Esquinas redondeadas
Abgerundeten Ecken

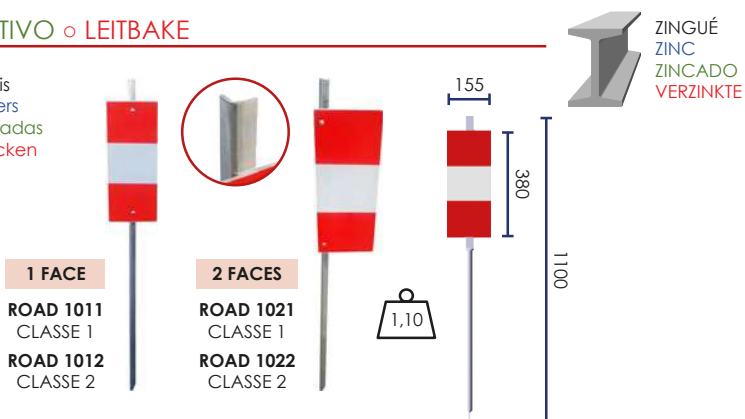

ZINGUÉ
ZINC
ZINCADO
VERZINKTE

GRILLAGE ◦ FENCE ◦ MALLA DE PROTECCIÓN ◦ FLEXIBLER ZAUN / ABSPERRNETZ

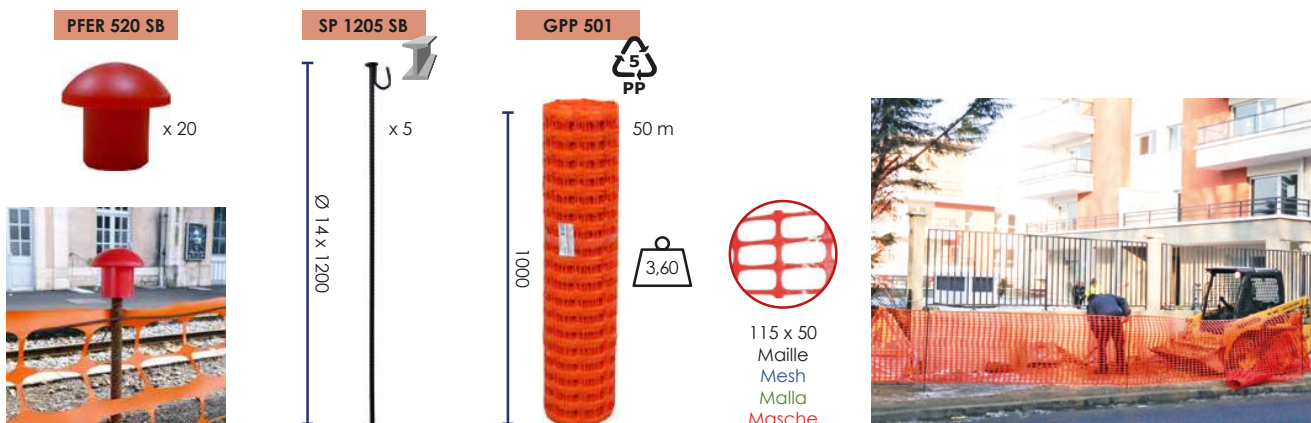



BAR 001 RB

BARELEC

BAR 002 RB

BARRIÈRE EXTENSIBLE

EXPANDABLE BARRIER ◦ BARRERA EXTENSIBLE ◦ ABSPERR-SCHERENGITTER

BAR 001 RB 2,30 m



Option ◦ Optional
Opción ◦ Optional

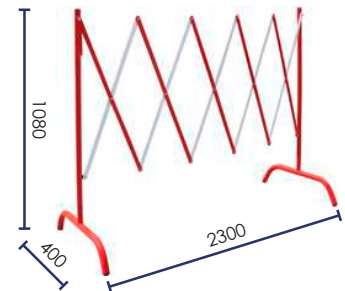

BAR 002 RB 1,30 x 1,30 m



Option ◦ Optional
Opción ◦ Optional

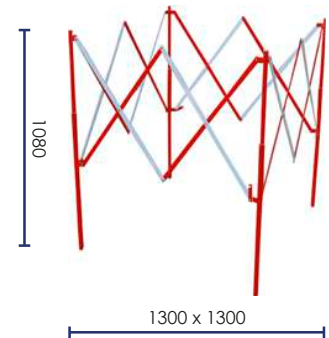

BARELEC 1,06 x 1,06 m



Option ◦ Optional
Opción ◦ Optional

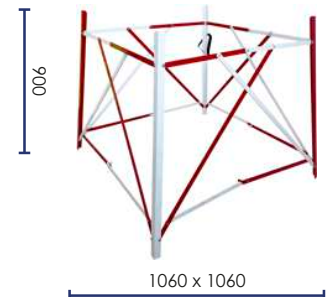

OPTION ◦ OPTIONAL ◦ OPCIÓN ◦ OPTIONAL



BAR 02 BAG
BARELEC
BAR 002



BAR 01 BAG



RS A4 PN
BAR 001
BAR 002

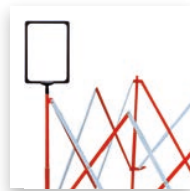



BAR 4000



BAR 3000

BARRIÈRE EXTENSIBLE ◦ **EXPANDABLE BARRIER**
BARRERA EXTENSIBLE ◦ **SCHERRENSPERREN**



Code	
BAR 3000 RB	
BAR 3000 BK	

3,00 m



BAR 3000 BK

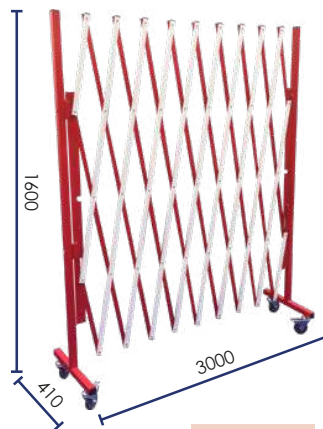

BAR 3000 RB



BAR 3 EXT RB

Code	
BAR 3 EXT RB	
BAR 3 EXT BK	

3,00 m



Ø 80

Code	
BAR 4000	
BAR 4000 NJ	
BAR 4000 BK	

4,00 m

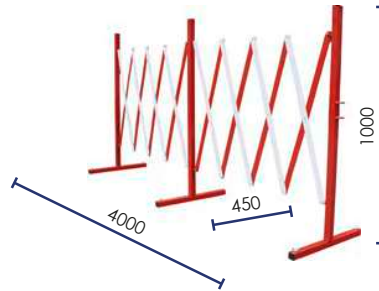
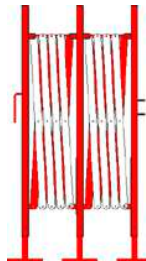

BAR 4000



Code	
BAR 4006 RB	
BAR 4006 NJ	
BAR 4006 BK	

4,00 m



Frein
 Brake
 Freno
 Bremse

WH 501 SB
 Ø 50 mm



BAR 4006 RB

OPTION ◦ **OPTIONAL** ◦ **OPCIÓN** ◦ **OPTIONAL**

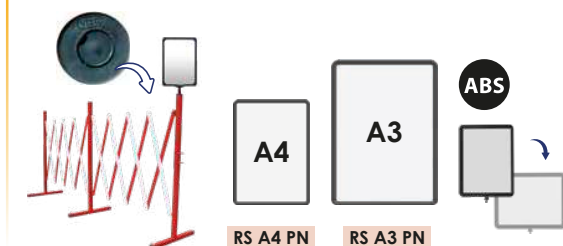

RS A4 PN

RS A3 PN

ABS

Frein
 Brake
 Freno
 Bremse

WH 501 SB
 Ø 50 mm

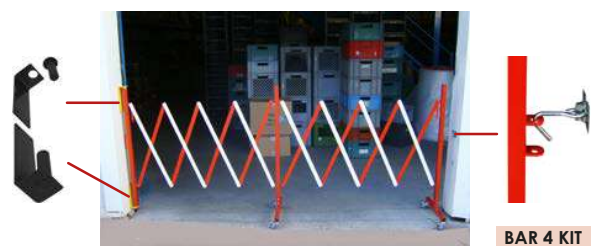

BAR 4 KIT

Kit de fixation murale ◦ Wall fixing kit
 Kit de fijación a la pared
 Wandbefestigungsset





FLEXPLO

EXTENSIO

BARRIÈRE EXTENSIBLE ◦ **EXPANDABLE BARRIER**
BARRERA EXTENSIBLE ◦ **ABSPERR-SCHERENGITTER**



FLEXPLO ◀▶ 2,00 m

Code		
FLEXPLO 200 RB		4,80
FLEXPLO EXTRB		3,40
FLEXPLO 200 NJ		4,80
FLEXPLO EXTNJ		3,40

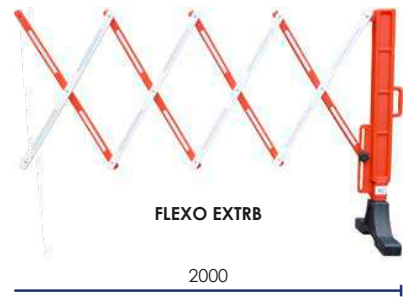
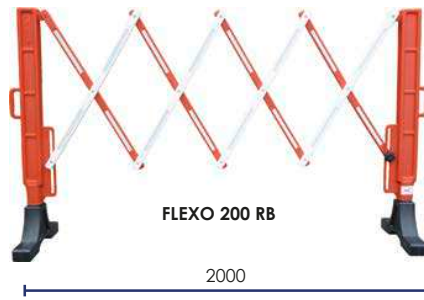
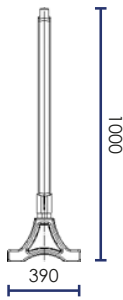

EXTENSIO ◀▶ 2,40 m

Code		
EXTENSIO		7,50
EXTENSIO JA		7,50

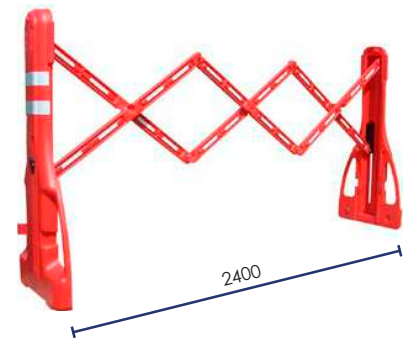
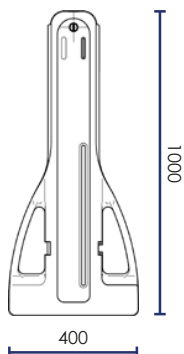
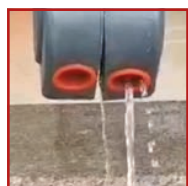

OPTION ◦ OPTIONAL ◦ OPCIÓN ◦ OPTIONAL



FLASH 90



LAMPSOL 180

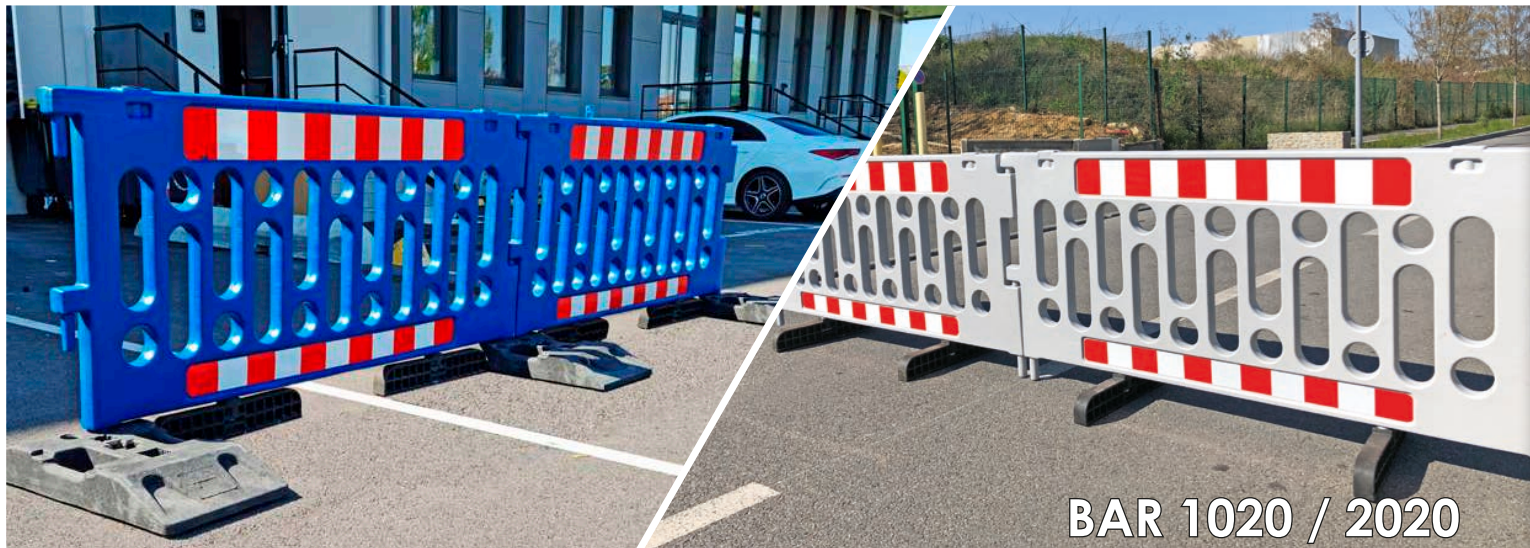

BARRIÈRES POLYPROPYLENE

POLYPROPYLENE BARRIERS

BARRERAS DE POLIPROPILENO ◦ SPERRGITTER



Classe 1 ◦ Class 1
Clase 1 ◦ Klasse 1



Autres couleurs : mini 50
Others colors : mini 50
Otros colores : mini 50
Andere Farben : Mini 50



Code		
BAR 2020 GR	RAL 7035	
BAR 2020 OR	RAL 2004	

Pieds intégrés
With heavy feet
Pies integrados
Integrierte Füße

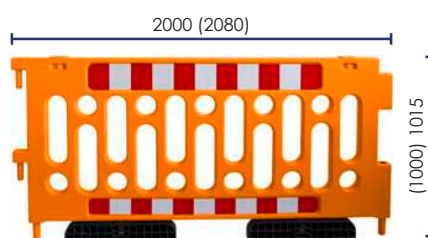
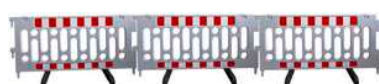

BAR 2020 OR

Code		
BAR 2020 GR SP	RAL 7035	
BAR 2020 OR SP	RAL 2004	

Pour base
For base
Para base
Für sockel

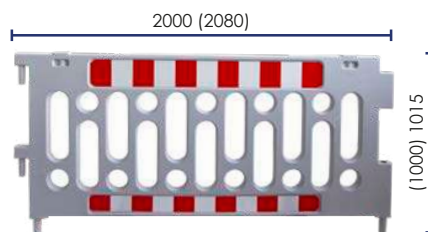

BAR 2020 GR SP

Code		
BAR 1020 GR	RAL 7035	
BAR 1020 OR	RAL 2004	

Pour base
For base
Para base
Für sockel

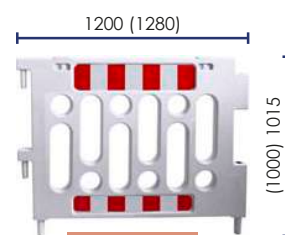

BAR 1020 GR

OPTION ◦ OPTIONAL ◦ OPCIÓN ◦ OPTIONAL

BASE 2500

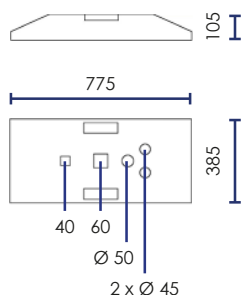

BASE 310

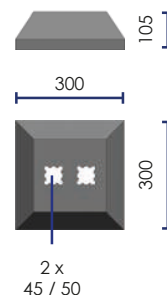

Poignée intégrée
Built in handle
Mango incorporado
Handgriff

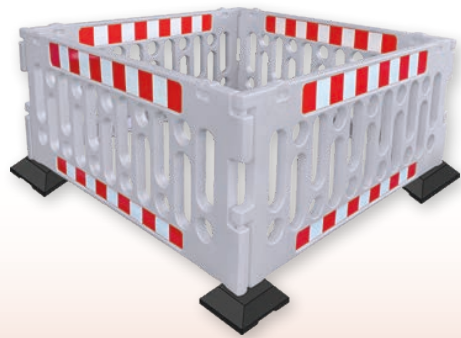

1200 X 1200

BAR 104 OR



BAR 134 OR



BAR 104 GR

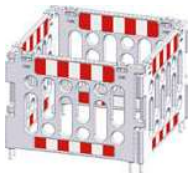

BAR 134 GR



2000 X 2000

BAR 204 OR



BAR 234 OR



BAR 244 OR



BAR 204 GR



BAR 234 GR



BAR 244 GR



OPTION ◦ OPTIONAL ◦ OPCIÓN ◦ OPORTIONAL

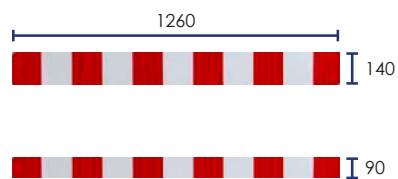
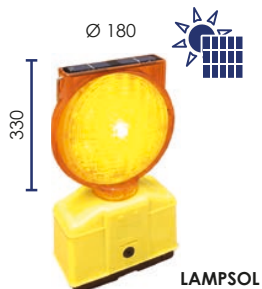

x 2
BARTAPE 2
Classe 2



RUBAN DE SIGNALISATION

WARNING TAPE ◦ CINTA DE SEÑALIZACIÓN ◦ ABSPERRBÄNDER



IMPRESSION 1 FACE ◦ 1 SIDE PRINTING ◦ IMPRESIÓN A 1 CARA ◦ 1-SEITIG BEDRUCKEN

Code	
RSNA 01 RB	x 36
RSNA 121 RB	x 12
RSNA 01 NJ	x 36
RSNA 121 NJ	x 12
RSNA 01 VE	x 36
RSNA 121 VE	x 12

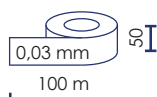

IMPRESSION 2 FACES ◦ 2 SIDES PRINTING ◦ IMPRESIÓN A 2 CARAS ◦ 2-SEITIG BEDRUCKEN

Code	
RSNA 02 RB	x 36

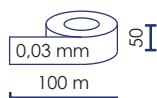

Code	
RSNA 580 RB	x 6
RSNA 580 BU	x 6

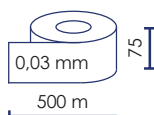

ACCESSOIRES ◦ ACCESSORIES
ACCESORIOS ◦ ZUBEHÖR

PFER 520 SB



SP 1205 SB



Ø 14 x 1200



CHAINE POLYPRO ET ACCESSOIRES

POLYPROPYLENE CHAIN ◦ CADENA DE PLÁSTICO ◦ KUNSTSTOFFKETTEN



Code	
CFLUO 825 SBS	○
CNJ 801 SBS	●
CBR 801 SBS	●
CPB 801 SBS	○
CPR 801 SBS*	●
CBV 801 SBS	●
CBB 801 SBS	●
CPN 801 SBS	●

25 m - Ø 8



CFLUO 825 SBS



Accessoires ► p. 175
Accessories ► p. 175
Accesorios ► p. 175
Zubehör ► p. 175

* Epuisement stock ◦ While stock lasts ◦ Hasta agotar existencias ◦ Lagerinventar Begrenzung



BANDEAU DE SIGNALISATION TISSU ○ **HIGH VISIBILITY WARNING STRIP**
BANDA DE ADVERTENCIA ALTA VISIBILIDAD ○ **BAND MIT HOHER SICHTBARKEIT**



5 M



Bandes lestées
 Weighted bottom
 Bandas lastradas
 unten des Bands gewichtet

GUI 500 OR

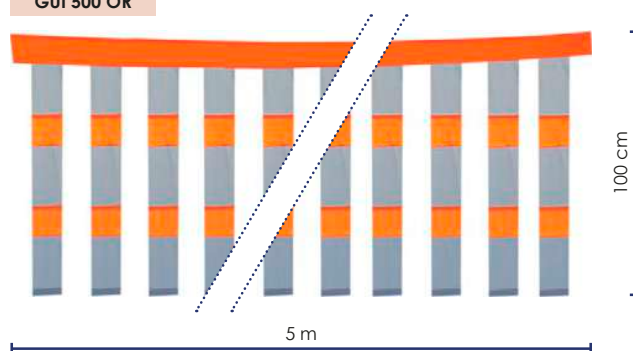

20 M



Bandes réfléchissantes
 Reflective tapes
 Tiras reflectantes
 Reflektierende Streifen

GUI 200 OR

CLASSE 1

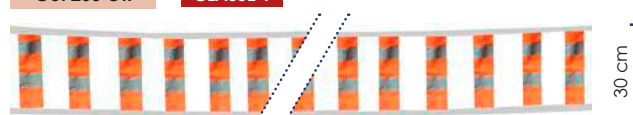

GUI 200 RB

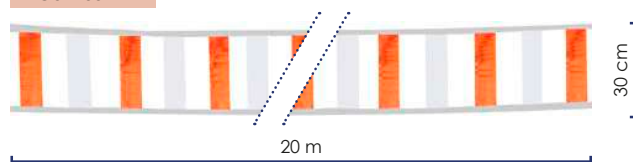

INCLUS ○ **INCLUDED** ○ **INCLUIDO** ○ **INKLUSIVE**



Sac de rangement
 Storage bag
 Bolsa de almacenamiento
 Aufbewahrungstasche

OPTION ○ **OPTIONAL** ○ **OPCIÓN** ○ **OPTIONAL**

ENR 200 ROUTE
 87 x 28 cm

ROUTE BARREE

ENR 200 ACCES
 87 x 28 cm

ACCES INTERDIT

ENR 200 SI
 29 x 27 cm





BARRIÈRE AVEC ENROULEUR ◦ **EXPANDABLE / RETRACTABLE BARRIER**
BARRERA DE SEÑALIZACIÓN CON ENROLLADOR ◦ **EINZIEHBARE ABSPERROLLE**



390 x 120 x 270 4,0



ENR 200 OR
 Réfléchissant
 Reflective
 Reflektivo
 Reflektierend

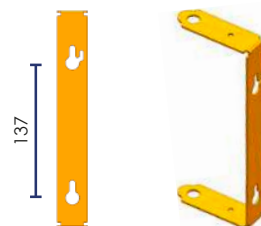

ENR 200 RB



ENR 200 NJ

INCLUS ◦ **INCLUDED**
INCLUIDO ◦ **INKLUSIVE**



OPTION ◦ **OPTIONAL** ◦ **OPCIÓN** ◦ **OPTIONAL**

ENR 200 ROUTE
 87 x 28 cm

ROUTE BARREE

ENR 200 ACCES
 87 x 28 cm

ACCES INTERDIT

ENR 200 SI
 29 x 27 cm





ENR 200

OPTIONS ○ **OPTIONS** ○ **OPCIONES** ○ **OPTIONEN**

ENR BOX

500 x 200 x H 480



Porte coulissante
Sliding door
Puerta corrediza
Schiebetürsystem



ENR POST 140



Poteau support et récepteur
Fixing post and receiver
Poste soporte y receptor
Doppelte Funktion: Träger und Empfänger

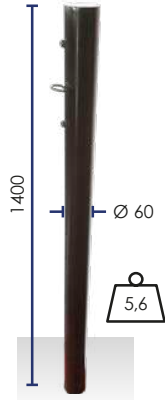

BASE 2500

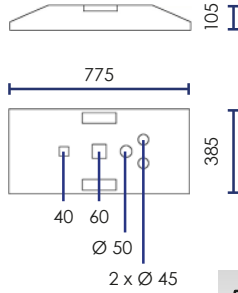

ENR 200 + BBASE

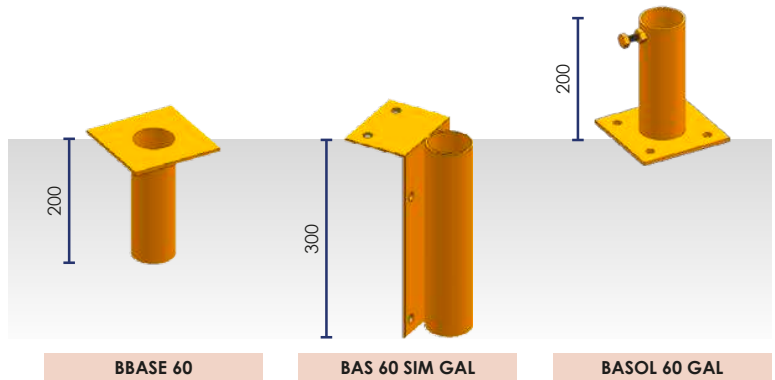

BBASE 60

BAS 60 SIM GAL

BASOL 60 GAL

ACCESSOIRES ◦ ACCESSORIES ◦ ACCESORIOS ◦ ZUBEHÖR

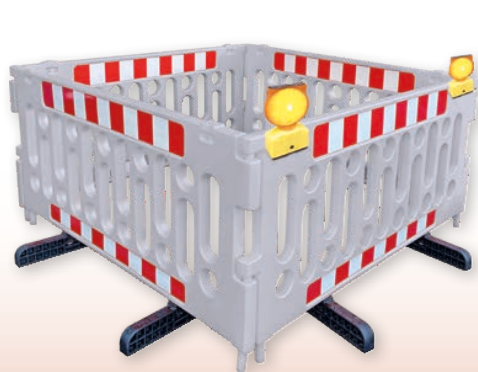

LAMPES ◦ SAFETY LAMPS ◦ LUZ DE SEÑALIZACIÓN ◦ SIGNALISIERUNG

LAMPSOL 180



LAMPSOL

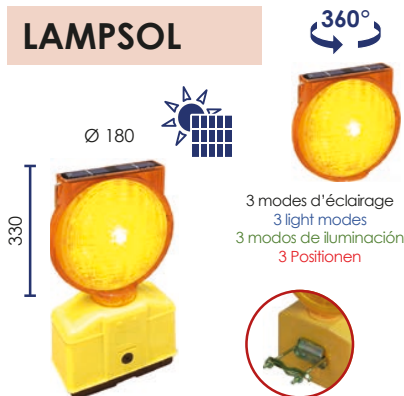

FLASH 90

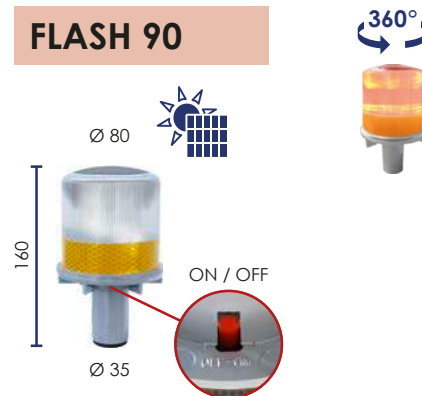

FLASH 101OR

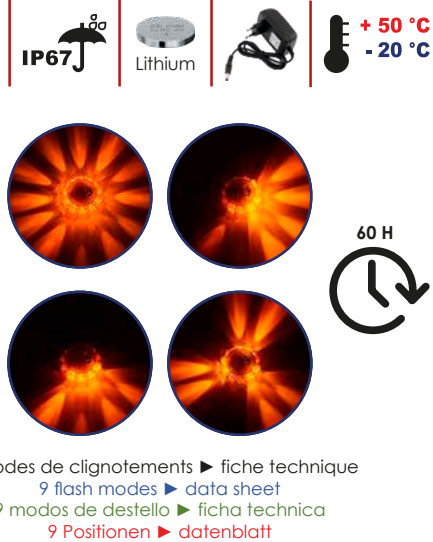

FAR 001

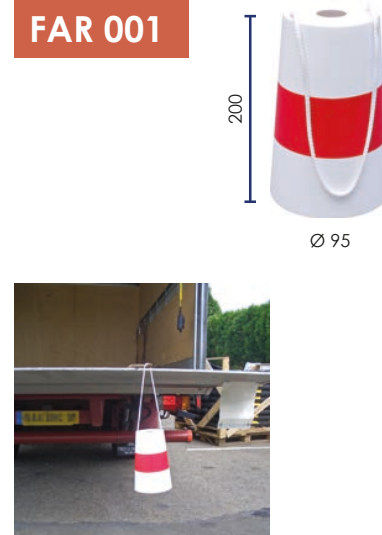

VESTES DE SÉCURITÉ ◦ SAFETY VEST ◦ CHALECO DE SEGURIDAD ◦ SICHERHEITSJACKE

ISO 20471 ◦ Taille unique XL ◦ XL size ◦ Talla XL ◦ Einzelne Größe XL



VJXL



VRXL



BRAJ 01 3M
47 x 7,5 cm



BRAR 01 3M
47 x 7,5 cm



TRAVO 100



TRAVOLITE



TRAVO 180



TRAVO 228



TRAVO 128



PARAVENT / BARRIÈRE DE PROTECTION

- Auto portante
- 2 hauteurs : 1 m ou 1,80 m
- En 3 vantaux
- Inox ou PVC
- Repliable
- Tissus à assembler sur l'armature par le client
- Tissu imprimé 1 face.
- Panneaux décoratifs avec velcro :
 - ▷ Facile à mettre en place
 - ▷ Facile à tendre
 - ▷ Tissus lavables

SCREEN / PROTECTION BARRIER

- Self Standing
- 2 heights: 1 m or 1.80 m
- In 3 panels
- Stainless steel or PVC
- Foldable
- Fabrics to be mounted on the frame by the customer
- 1 side printed fabric
- Decorative panels with velcro :
 - ▷ Easy to put in place
 - ▷ Easy to stretch
 - ▷ Washable fabrics

BIOMBO / BARRERA DE SEÑALIZACIÓN

- Estructura autoportante
- 2 alturas: 1 m o 1,80 m
- De 3 paneles
- Acero inoxidable o PVC
- Plegable
- Armados de los tejidos en el marco por el cliente
- Tejido impreso a 1 cara
- Paneles decorativos con velcro :
 - ▷ Fácil de colocar
 - ▷ Fácil de tender
 - ▷ Tejidos lavables

SCHUTZ BARRIERE / SICHTSCHUTZ

- Freistehend
- Höhe : 1 m oder 1,8m
- 3 Sicht- / Schutzfelder
- Ständer Ausführung in Stahl oder Kunststoff
- Faltbar
- Montage der Elemente vor Ort durch Kunden
- 1 Seite ist bedruckt.
- Bespannung mit Klettverschluss :
 - ▷ einfach zu montieren
 - ▷ ist dehnbar
 - ▷ waschbar

PERSONNALISATION ◦ CUSTOMIZATION ◦ PERSONALIZACIÓN ◦ PERSONALISIERUNG

TRAVO PRINT

Minimum 15 barrières (de 3 panneaux) ◦ Minimum order 15 barriers (3 panels)
 Pedido mínimo: 15 barreras (3 paneles)
 Mini Bestellungen 15 Absperrungen (3 Sicht- / Schutzfelder)

TYPE DE TISSU ◦ FABRIC CHOICE

TIPO DE TEJIDO ◦ STOFFAUSWAHL



IGNIFUGE

Tissu ignifugé, impression 3 couleurs
Flame retardant fabric, 3 colors printing
Tejido ignífugo, Impresión a 3 colores
Flammfestes Gewebe, 3 Farben-Druck



Tissu brise vent, impression 3 couleurs
Windproof fabric, 3 colors printing
Tejido cortaviento, Impresión a 3 colores
Winddichtes Gewebe, 3 Farben-Druck



Tissu standard, impression quadri
Standard fabric, 4 colors printing
Tejido estándar, Impresión a 4 colores
Standard Gewebe, 4 Farben-druck



COULEUR

COLOR ◦ COLOR ◦ FARBEN



Personnalisation
 Customization
 Personalización
 Personalisierung

Standard
 Standard
 Estándar
 Standard

FIXATION TISSU ◦ FABRIC FIXATION

FIJACIÓN DEL TEJIDO ◦ GEWEBE BEFESTIGUNGS



Velcro
 Délai 5 semaines
 Lead-time 5 weeks
 Plazo de entrega : 5 semanas
 Frist 5 Wochen



Cousu, délai 10 semaines
Sewn, within 10 weeks
Cosido, plazo de 10 semanas
Genäht, Frist 10 Wochen



OPTION
 OPTIONAL
 OPCIÓN
 OPTIONAL



TRAVOBAG 100



TRAVOFEET 128

Pour
 For
 Para
 Für
 TRAVO 128 / 228



TRAVOBASE

Pour
 For
 Para
 Für
 TRAVO 100 / 180



TRAVO 100

VERSION CLASSIQUE ◦ CLASSIC VERSION ◦ VERSIÓN CLÁSICA ◦ KLASSISCHE VERSION

- **Structure PVC** (4,2 kg - H 1 m)
 - ▷ Légère, maniable et facilement transportable
 - ▷ Jonction en PVC pour maintenir les panneaux entre eux
 - ▷ Facile à déplier et replier
 - ▷ Utilisable en milieu humide
 - ▷ Ne craint pas la pluie
- **PVC structure** (4.2 kg - H 1 m)
 - ▷ Lightweight, easy to use and transport
 - ▷ PVC link to hold the panels together
 - ▷ Easy to unfold and fold
 - ▷ Can be used in a humid environment
 - ▷ Rain resistant
- **Estructura de PVC** (4.2 kg - H 1 m)
 - ▷ Ligero, fácil de usar y transportar
 - ▷ Enlace de PVC para unir los paneles
 - ▷ Fácil de desplegar y plegar
 - ▷ Puede usarse en un ambiente húmedo
 - ▷ Resistente a la lluvia
- **PVC- Material-Struktur** (Gewicht 4.2 kg - H 1 m)
 - ▷ Geringes Gewicht, handlich und leicht zu transportieren
 - ▷ Verbindungselemente aus Kunststoff
 - ▷ Leicht zu entfalten und zusammenlegen
 - ▷ In feuchter Umgebung verwendbar
 - ▷ Regen resistent



TRAVOLITE



TRAVO 100

BARRIÈRE D'INTERVENTION LÉGÈRE o PVC PROTECTION BARRIER BARRERA DE SEÑALIZACIÓN EN PVC o LEICHTE ABSPERRUNG

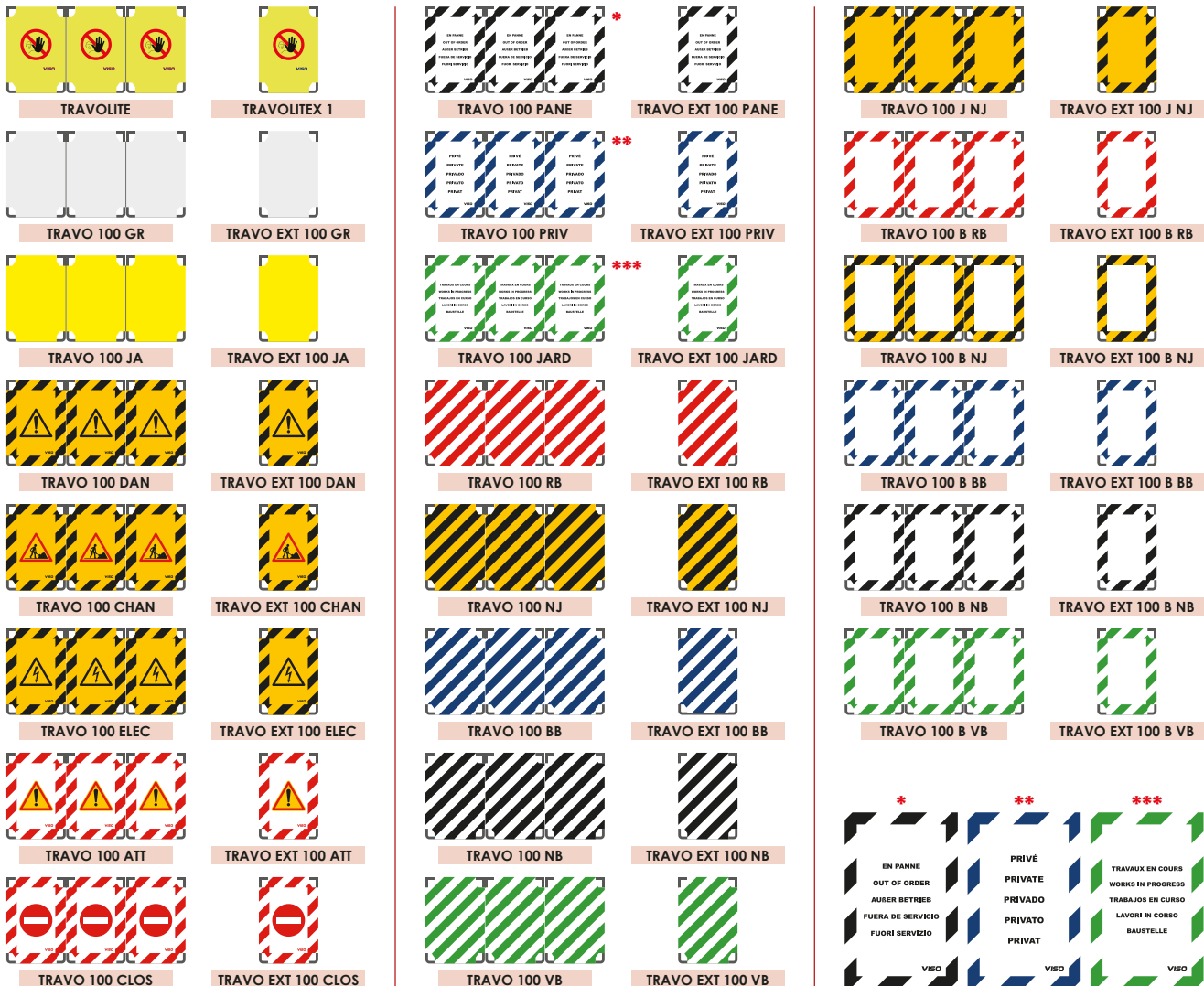

TRAVO 128

VERSION DESIGN ◦ VERSIÓN DESIGN ◦ VERSIÓN DESIGN ◦ DESIGN VERSION

- **Structure Inox** (10,5 kg - H 1 m)
 - ▷ Charnières boulonnées pour maintenir les panneaux entre eux
 - ▷ Stabilité renforcée
 - ▷ Intérieur / Extérieur
 - ▷ Convient en milieu humide
 - ▷ Ne craint pas la pluie
- **Stainless steel structure** (10,5 kg - H 1 m)
 - ▷ Bolt-on hinges to hold panels together
 - ▷ Reinforced stability
 - ▷ Indoor / Outdoor
 - ▷ Can be used in a humid environment
 - ▷ Rain resistant
- **Estructura de acero inoxidable** (10,5 kg - H 1 m)
 - ▷ Bisagras atornilladas para unir los paneles
 - ▷ Estabilidad reforzada
 - ▷ Interior / Exterior
 - ▷ Puede usarse en un ambiente húmedo
 - ▷ Resistente a la lluvia
- **Edelstahlkonstruktion** (Gewicht 10,5 kg - H 1 m)
 - ▷ Anschraubbare Scharniere zum Zusammenhalten der Paneele.
 - ▷ Verstärkte Stabilität
 - ▷ Anwendung: Innen / Außen
 - ▷ Geeignet in feuchter Umgebung
 - ▷ Regen resistent
- **Möglichkeit der Langzeitfixierung** mittels Boden-Platten





TRAVO 128

BARRIÈRE D'INTERVENTION INOX ◦ STAINLESS STEEL PROTECTION BARRIER BARRERA DE SEÑALIZACIÓN EN ACERO INOXIDABLE ◦ ABSPERRUNG AUS INOX

TRAVO EXT 128



0,57 m

TRAVO 128



1,70 m

1,00 m



TRAVOFEET 128 / Option ◦ Optional ◦ Opción ◦ Optional



TRAVO 128 INT



TRAVO EXT 128 INT



TRAVO 128 PANE



TRAVO EXT 128 PANE



TRAVO 128 J NJ



TRAVO EXT 128 J NJ

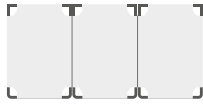

TRAVO 128 GR



TRAVO EXT 128 GR



TRAVO 128 PRIV



TRAVO EXT 128 PRIV



TRAVO 128 B RB



TRAVO EXT 128 B RB

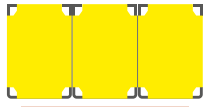

TRAVO 128 JA



TRAVO EXT 128 JA



TRAVO 128 JARD



TRAVO EXT 128 JARD



TRAVO 128 B NJ



TRAVO EXT 128 B NJ



TRAVO 128 DAN



TRAVO EXT 128 DAN



TRAVO 128 RB



TRAVO EXT 128 RB



TRAVO 128 B BB



TRAVO EXT 128 B BB



TRAVO 128 CHAN



TRAVO EXT 128 CHAN



TRAVO 128 NJ



TRAVO EXT 128 NJ



TRAVO 128 B NB



TRAVO EXT 128 B NB



TRAVO 128 ELEC



TRAVO EXT 128 ELEC



TRAVO 128 BB



TRAVO EXT 128 BB



TRAVO 128 B VB



TRAVO EXT 128 B VB



TRAVO 128 ATT



TRAVO EXT 128 ATT

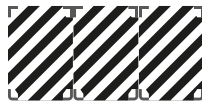

TRAVO 128 NB



TRAVO EXT 128 NB



TRAVO 128 VB



TRAVO EXT 128 VB



TRAVO 128 CLOS



TRAVO EXT 128 CLOS



TRAVO 128 VB



TRAVO EXT 128 VB

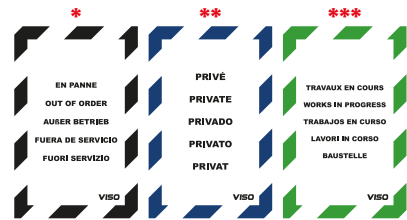

OPTION
OPTIONAL
OPCIÓN
OPTIONAL

TRAVOBAG 100



TRAVOFEET 128



TRAVO 180

VERSION CLASSIQUE ◦ CLASSIC VERSION ◦ VERSIÓN CLÁSICA ◦ KLASSISCHE VERSION

- **Structure PVC** (6,5 kg - H 1,80 m)
 - ▷ Légère, maniable et facilement transportable
 - ▷ Jonction en PVC pour maintenir les panneaux entre eux
 - ▷ Facile à déplier et replier
 - ▷ Utilisable en milieu humide
 - ▷ Ne craint pas la pluie
- **PVC structure** (6,5 kg - H 1,80 m)
 - ▷ Lightweight, easy to use and transport
 - ▷ PVC link to hold the panels together
 - ▷ Easy to unfold and fold
 - ▷ Can be used in a humid environment
 - ▷ Rain resistant
- **Estructura de PVC** (6,5 kg - H 1,80 m)
 - ▷ Ligero, fácil de usar y transportar
 - ▷ Enlace de PVC para unir los paneles
 - ▷ Fácil de desplegar y plegar
 - ▷ Puede usarse en un ambiente húmedo
 - ▷ Resistente a la lluvia
- **PVC- Material-Struktur** (Gewicht 6,5kg - H 1,80 m)
 - ▷ Geringes Gewicht, handlich und leicht zu transportieren
 - ▷ Verbindungselemente aus Kunststoff
 - ▷ Leicht zu entfalten und zusammenlegen
 - ▷ In feuchter Umgebung verwendbar
 - ▷ Regen resistent



OPTION
OPTIONAL
OPCIÓN
OPTIONAL

TRAVOBAG 180





TRAVO 180

BARRIÈRE D'INTERVENTION LÉGÈRE o PVC PROTECTION BARRIER
BARRERA DE SEÑALIZACIÓN EN PVC o LEICHTE ABSPERRUNG



TRAVO 180 INT



TRAVO EXT 180 INT

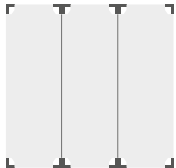

TRAVO 180 GR



TRAVO EXT 180 GR

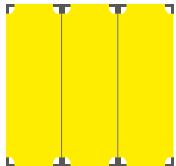

TRAVO 180 JA



TRAVO EXT 180 JA



TRAVO 180 DAN



TRAVO EXT 180 DAN



TRAVO 180 CHAN



TRAVO EXT 180 CHAN



TRAVO 180 ELEC



TRAVO EXT 180 ELEC



TRAVO 180 ATT



TRAVO EXT 180 ATT



TRAVO 180 CLOS



TRAVO EXT 180 CLOS



TRAVO 180 PANE



TRAVO EXT 180 PANE



TRAVO 180 PRIV



TRAVO EXT 180 PRIV



TRAVO 180 JARD



TRAVO EXT 180 JARD

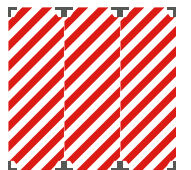

TRAVO 180 RB



TRAVO EXT 180 RB



TRAVO 180 NJ



TRAVO EXT 180 NJ

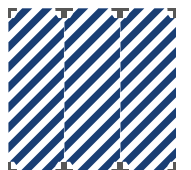

TRAVO 180 BB



TRAVO EXT 180 BB

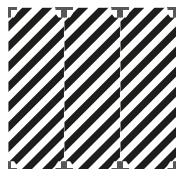

TRAVO 180 NB



TRAVO EXT 180 NB

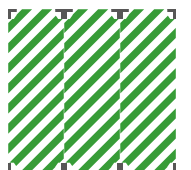

TRAVO 180 VB



TRAVO EXT 180 VB



TRAVO 180 J NJ



TRAVO EXT 180 J NJ



TRAVO 180 B RB



TRAVO EXT 180 B RB



TRAVO 180 B NJ



TRAVO EXT 180 B NJ

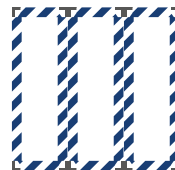

TRAVO 180 B BB



TRAVO EXT 180 B BB



TRAVO 180 B NB



TRAVO EXT 180 B NB



TRAVO 180 B VB



TRAVO EXT 180 B VB



TRAVO 180 PANE

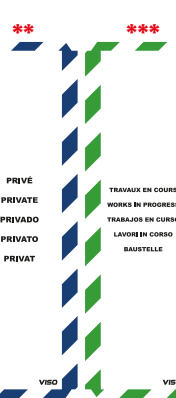

TRAVO 180 PRIV



TRAVO 180 JARD

EN PANNE
OUT OF ORDER
AUSER BETREB
FUERA DE SERVICIO
FUORI SERVIZIO

PRIVÉ
PRIVATE
PRIVATO
PRIVAT

TRAVAUX EN COURS
WORKS IN PROGRESS
TRABAJO EN CURSO
LAVORI IN CORSO
BAUSTELLE

VISO

TRAVO 228

VERSION DESIGN ◦ VERSIÓN DESIGN ◦ VERSIÓN DESIGN ◦ DESIGN VERSION

- **Structure Inox** (18 kg - H 1,80 m)
 - ▷ Charnières boulonnées pour maintenir les panneaux entre eux
 - ▷ Stabilité renforcée
 - ▷ Intérieur / Extérieur
 - ▷ Convient en milieu humide
 - ▷ Ne craint pas la pluie
- **Stainless steel structure** (18 kg - H 1,80 m)
 - ▷ Bolt-on hinges to hold panels together
 - ▷ Reinforced stability
 - ▷ Indoor / Outdoor
 - ▷ Can be used in a humid environment
 - ▷ Rain resistant
- **Estructura de acero inoxidable** (18 kg - H 1,80 m)
 - ▷ Bisagras atornilladas para unir los paneles
 - ▷ Estabilidad reforzada
 - ▷ Interior / Exterior
 - ▷ Puede usarse en un ambiente húmedo
 - ▷ Resistente a la lluvia
- **Edelstahlkonstruktion** (Gewicht 18 kg - H 1,80 m)
 - ▷ Anschraubbare Scharniere zum Zusammenhalten der Paneele.
 - ▷ Verstärkte Stabilität
 - ▷ Anwendung: Innen / Außen
 - ▷ Geeignet in feuchter Umgebung
 - ▷ Regen resistent
- Possibilité de fixation longue durée avec des platines
- Possibility of long-term fixing thanks to the fixing plate
- Posibilidad de fijación a largo plazo gracias a la placa de fijación
- Möglichkeit der Langzeitfixierung mittels Boden-Platten

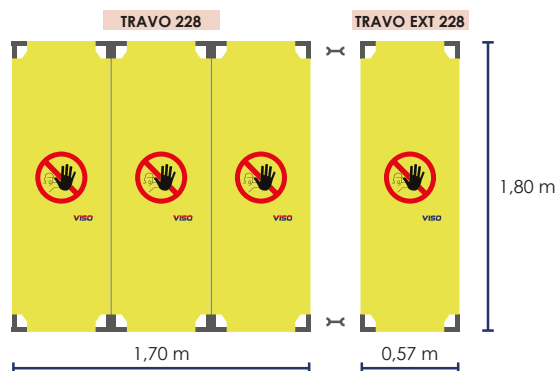

OPTION
OPTIONAL
OPCIÓN
OPTIONAL

TRAVOBAG 180



TRAVOFEET 128



TRAVO 228

BARRIÈRE D'INTERVENTION INOX ◦ STAINLESS STEEL PROTECTION BARRIER
BARRERA DE SEÑALIZACIÓN EN ACERO INOXIDABLE ◦ **ABSPERRUNG AUS INOX**



TRAVO 228 INT



TRAVO EXT 228 INT

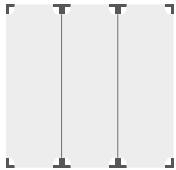

TRAVO 228 GR



TRAVO EXT 228 GR

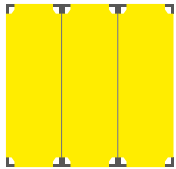

TRAVO 228 JA

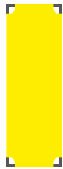

TRAVO EXT 228 JA



TRAVO 228 DAN



TRAVO EXT 228 DAN



TRAVO 228 CHAN



TRAVO EXT 228 CHAN



TRAVO 228 ELEC



TRAVO EXT 228 ELEC



TRAVO 228 ATT



TRAVO EXT 228 ATT



TRAVO 228 CLOS



TRAVO EXT 228 CLOS



TRAVO 228 PANE



TRAVO EXT 228 PANE



TRAVO 228 PRIV



TRAVO EXT 228 PRIV



TRAVO 228 JARD



TRAVO EXT 228 JARD



TRAVO 228 RB



TRAVO EXT 228 RB



TRAVO 228 NJ



TRAVO EXT 228 NJ

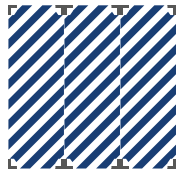

TRAVO 228 BB



TRAVO EXT 228 BB

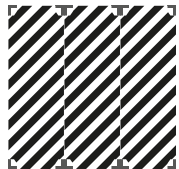

TRAVO 228 NB



TRAVO EXT 228 NB

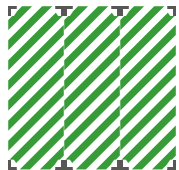

TRAVO 228 VB



TRAVO EXT 228 VB



TRAVO 228 J NJ



TRAVO EXT 228 J NJ



TRAVO 228 B RB



TRAVO EXT 228 B RB



TRAVO 228 B NJ



TRAVO EXT 228 B NJ



TRAVO 228 B BB



TRAVO EXT 228 B BB



TRAVO 228 B NB



TRAVO EXT 228 B NB



TRAVO 228 B VB



TRAVO EXT 228 B VB



TRAVO 228 PANE

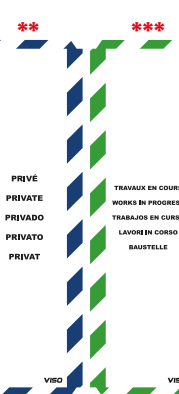

TRAVO 228 PRIV



TRAVO 228 JARD

EN PANE	PRIVÉ	TRAVAUX EN COURS
OUT OF ORDER	PRIVATE	WORKS IN PROGRESS
AUßER BETRIEB	PRIVATO	TRABAJO EN CURSO
FUORI SERVIZIO	PRIVAT	LAVORE IN CORSO
		BAUSTELLE
VISO	VISO	VISO